

Date of last update: Jul-04

Ref: D7.11.1/0603-0704/E

Application Engineering Europe

SEMI-HERMETIC COMPRESSORS - ADDITIONAL FANS

The additional fans are used to dissipate the motor-heat loss or to cool the cylinder heads. This depends on the compressor type, its application range and the refrigerant (see application tables in Copeland Selection Software and semi-hermetic compressor application guidelines).

The motor of the compressors DK and DL needs to be cooled by means of a water coil or an air flow.

Three different types of additional fan are used with our semi-hermetic compressors:

- Horizontal air flow fan 25 Watts
- Vertical air flow fan 7 Watts
- Vertical air flow fan 75 Watts

1 Horizontal fan 25 Watts

A 25-Watt horizontal fan can be used for ventilating DK and DL "air-cooled" compressors.

The single-phase motor is external-rotor motor with the fan blades permanently fixed to the rotor.

The fan motor, fan guard and fixing bracket are pre-assembled (see Fig. 1). The fan is laterally mounted at the compressor-fastening screws with two fixing straps (according to the instructions from the mounting kit). The fixing straps are included in the mounting kit and compensate the distance between the holes in the compressor feet.

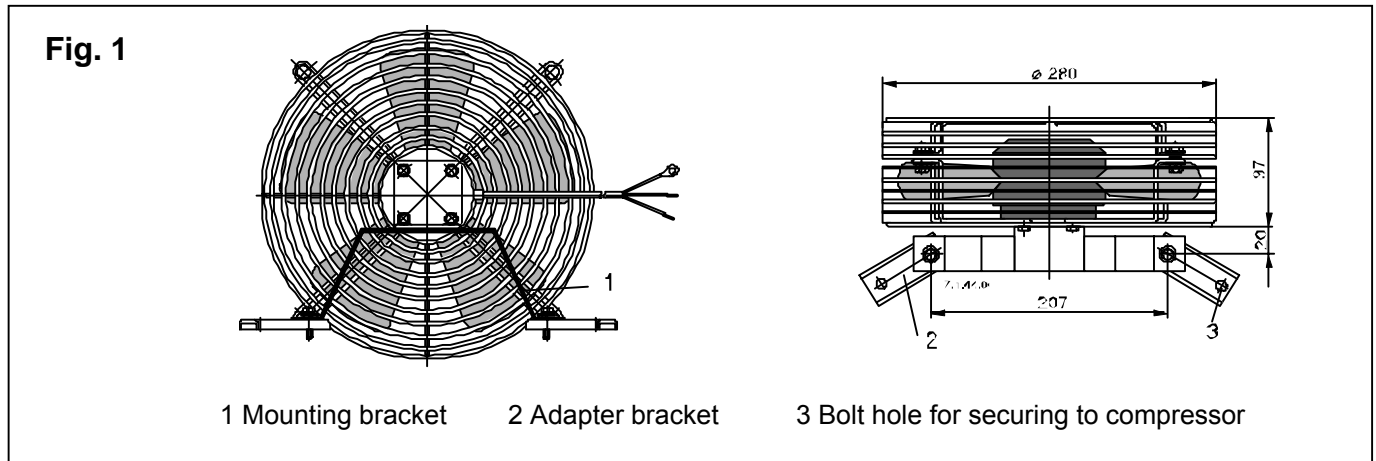

Caution: the fan must be mounted on the side of the discharge shut-off valve (see figures below).

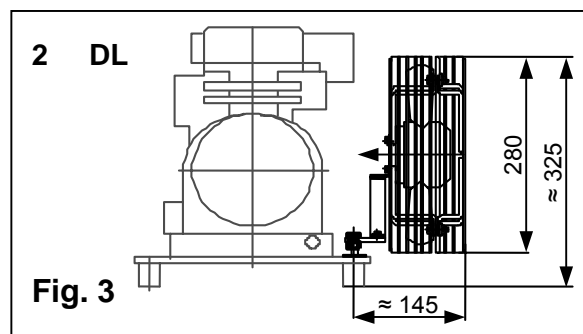
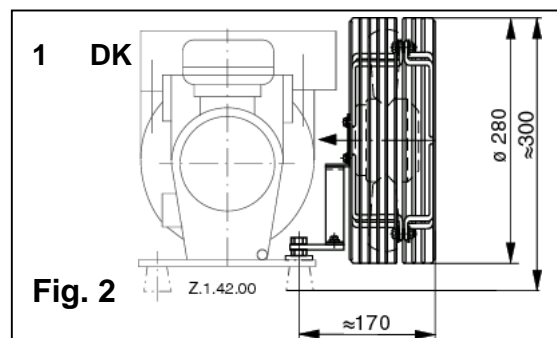

1.1 Technical Data of Fan 25 W

motor voltage $\pm 15\%$	230 V / 1 Ph	230 V / 1 Ph
frequency	50 Hz	60 Hz
current input	0.53 A	0.46 A
power input	72 W	
protection class (acc. To IEC 34)	IP 44	
connection cable (3 leads), length	600 mm	
connection cable, cross section	0.5 mm ²	
motor protection, n.c. (F10)	-	67 W
nominal voltage	250 V AC	
nom. Current at $\cos\Phi = 1$	2.5 A	
nom. Current at $\cos\Phi = 0.6$	1.6 A	
max. breaking current	5 A	

1.2 Wiring Diagram 25 W Fan

The fan motor can be connected via the terminal box of the compressor (see wiring diagram on terminal box cover of compressor). The 25-W fan has no terminal box. The three lead cable goes directly into the motor.

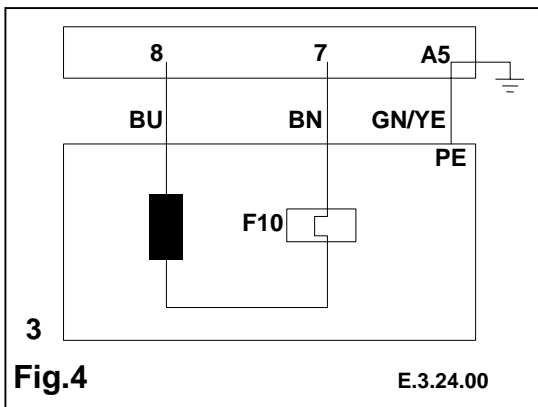

Legend (Figure4)

- A5** = Compressor terminal box
- F10** = Thermal protection switch of fan motor
- PE** = Earth connection
- BU** = Blue
- BN** = Brown
- GN/YE** = Green/Yellow

1.3 Caution (25 W Fan)

The thermal protection switch of the fan motor is in line with the mains. If the protector trips, only the fan will be switched off, and the compressor will no longer be cooled.
 Note that the compressor motor will still be protected by an over current thermal protection switch or thermistor protection. However, since there is no cylinder head cooling, the compressor is endangered.
 The addition of a current sensing relay to the fan motor connection that interrupts the control line of the compressor motor when the fan stops will help to avoid this situation.

2 Vertical fan 7 Watts

For cylinder head cooling of DK-compressors there is a 7 Watt fan available as option. It has a vertical airflow direction (see Fig. 5) and will be fixed directly to the cylinder head, mount the pre-assembled fan with the enclosed screws (5/16" – 18 UNC * 1,875").

Tightening torque 29 to 30 Nm
 Motor voltage 220 V – 1 Ph – 50 Hz
 Protection class (according to IEC 529) IP 42

The fan assembly consists of:

- Motor with fan blade
- Fan guard (1),
- Cover for fan guard (2)
- Two mounting brackets (3).

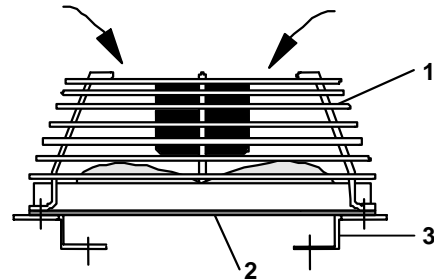

Fig. 5

3 Vertical fan 75Z

The 75Z is used on our compressors since July 1995, it is used for all compressor series (except DK). The complete fan consists of an external-rotor motor with the fan blades permanently fixed to the rotor and the fan guard.

3.1 Installation of the additional fan

For installation, a mounting kit that fits to each compressor is delivered with the fan or separately.

The fan can be ordered with the compressor as an accessory or separately as a spare part.

For D3D and D9R compressors, it must be specified whether there is a capacity control in order to receive the correct fixing bracket.

The 75Z fan is not compliant with the oil cooler when replacing a fan on a compressor fitted with an oil cooler, the previously used type of fan has to be used.

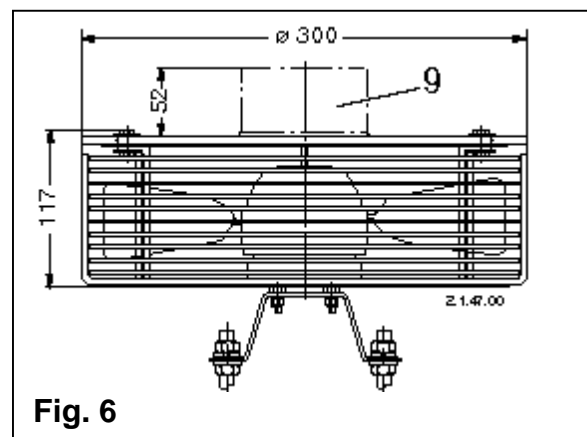

Fig. 6

3.2 Technical Data of Fan 75 Z

	Motor Voltage						
	230 V ±15%		230 V Δ ±15%		400 V Y ±15%		500 V Y +6/-10%
	1Ph/50Hz	1Ph/60Hz	3Ph/50Hz	3Ph/60Hz	3Ph/50Hz	3Ph/60Hz	3Ph/50Hz
Current Input	0.34 A	0.47 A	0.31 A	0.33 A	0.18 A	0.19 A	0.15 A
Power Input	75 W	103 W	70 W	96 W	70 W	96 W	70 W
Protection Class acc. to IEC 34)	IP 54						
Lead (Cores). Length	(3) / 600 mm		(9) / 600 mm		(9) / 600 mm		(6) / 600 mm
Lead, cross-section	0.5 mm ²						

3.3 Electrical Connection

The fan motor can be connected via the compressor terminal box (see wiring diagram on terminal box cover of compressor). The three-phase motors have no terminal box, the motor cables (6 or 9 leads) lead directly into the motor.

The single-phase motors have a terminal box for wiring the run capacitor (5µF/400V) and the motor (see Fig. 6, position 9). Here the connection will be done by a three lead cable to the terminal box of compressor.

3.3.1 Motor Protection (fan)

A thermal protection switch protects the fan motors. The protection switch of the three-phase operated fans **must** be looped into the control circuit otherwise the fan motor is not protected. For single-phase operated fan motors the thermal protection switch is in line with the power supply (see wiring diagrams).

3.3.2 Motor protection Technical Data

Normally closed		
Operating voltage AC	12-500 V	
Duty classification	< 10 /h	
Nominal voltage	250 V AC	500 V AC
Nom. current at $\cos\phi = 1$	2.5 A	0.75 A
Nom. current at $\cos\phi = 0.6$	1.6 A	0.5 A
Max. breaking current	5 A	2.5 A

3.3.3 Attention

If the thermal protection switch trips on single-phase operation only the fan will be switched off and the compressor will no longer be cooled.

The compressor motor will still be protected by an over current thermal protection switch or thermistor protection, but since there is no cylinder head cooling the compressor is endangered.

A current sensing relay to the fan motor connection that interrupts the control line of the compressor motor when the fan stops will help to avoid this situation.

3.3.4 Wiring Diagrams for Fan 75 Z

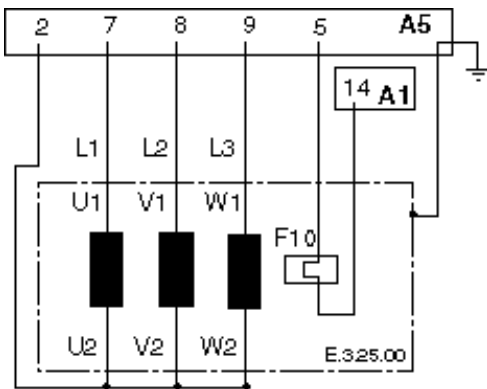

Fig.17 Star connection

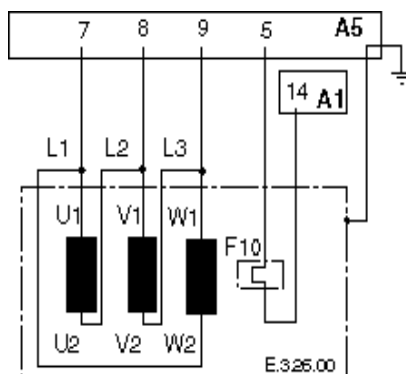

Fig.18 Delta Connection

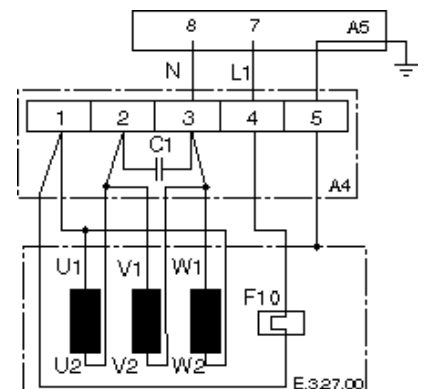

Fig.19 Steinmetz Connection for Single-phase operation

Legend

A1 = Module for compressor motor protection
A5 = Terminal box of compressor

A4 = Terminal box at single -phase operation
C1 = Run capacitor

Colour Code

U1 = Brown (BN)
U2 = Red (RD)

V1 = Blue (BU)
V2 = Grey (GY)

W1 = Black (BK)
W2 = Orange (OG)

F10 = White (WH)
PE = Green/Yellow (GN/YE)

Note

The fan must blow air towards the compressor!
Check the direction of rotation after electrical connection!

3.3.5 75 Z Fan Mounting

DL, DLH, D2S

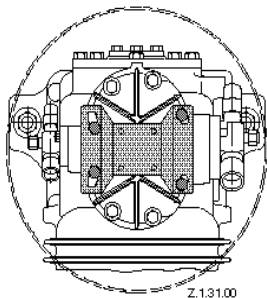
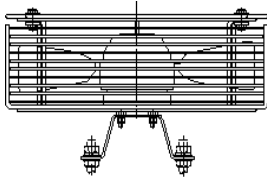

Z.1.31.00

D3S, D9R

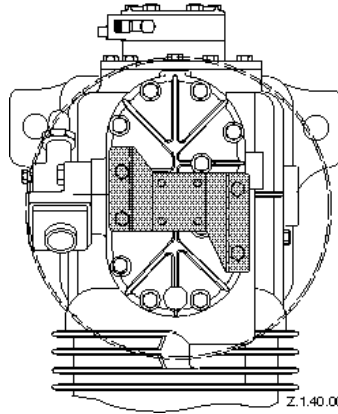
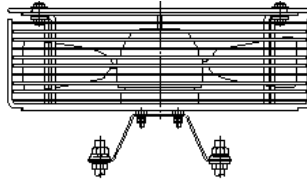

Z.1.40.00

D9R with Capacity control

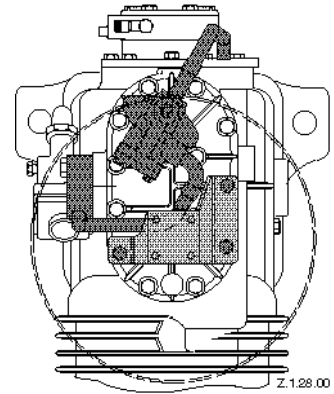
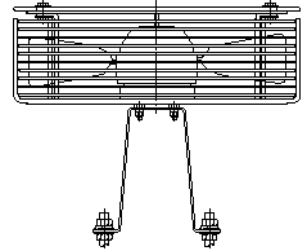

Z.1.28.00

D2D

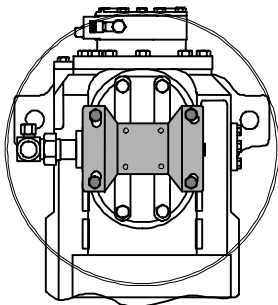
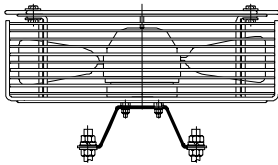

Z.1.32.00

D3D

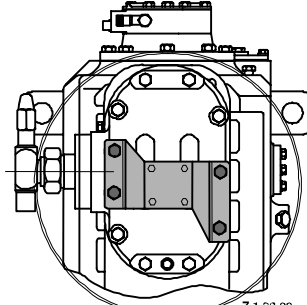
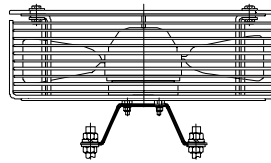

Z.1.29.00

D3D with Moduload

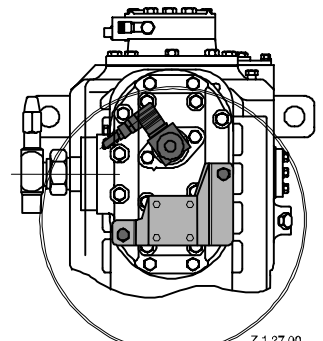
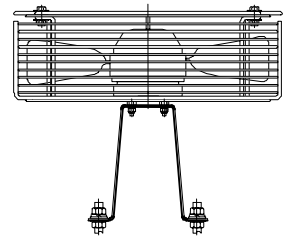

Z.1.27.00

D4SJ

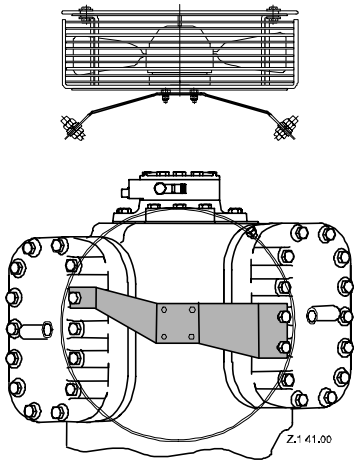

Other D4S

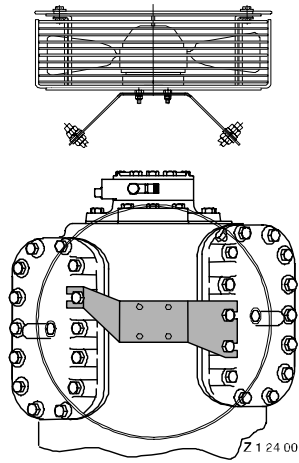

D4D

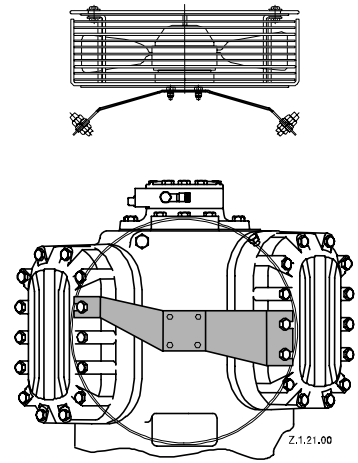

D6S, 6CC

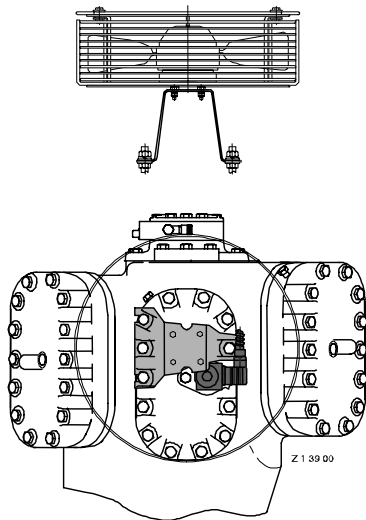

D6D

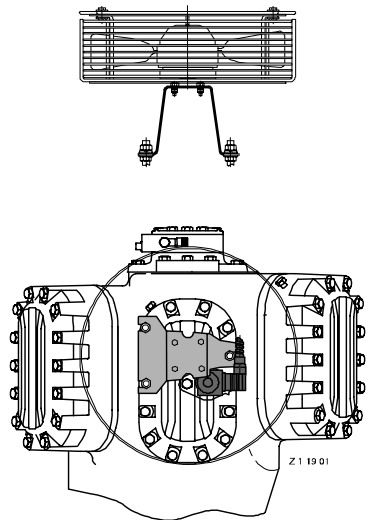

D8SH

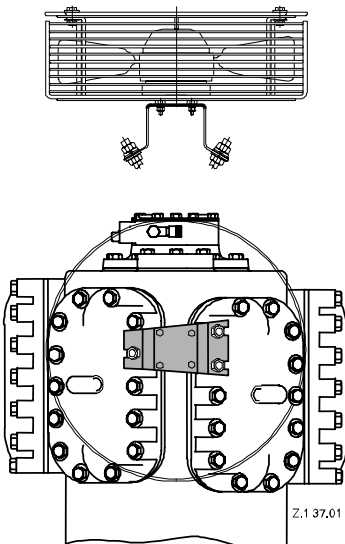

D8SJ, D8SK

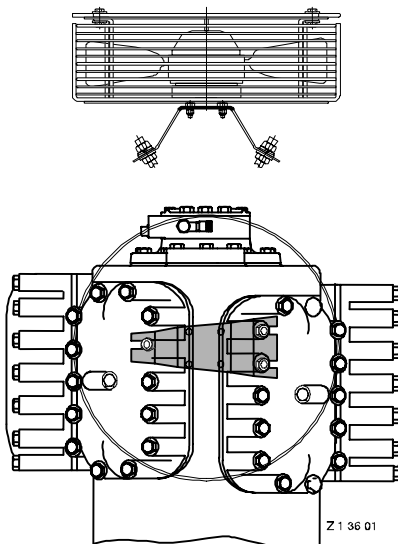

D8D

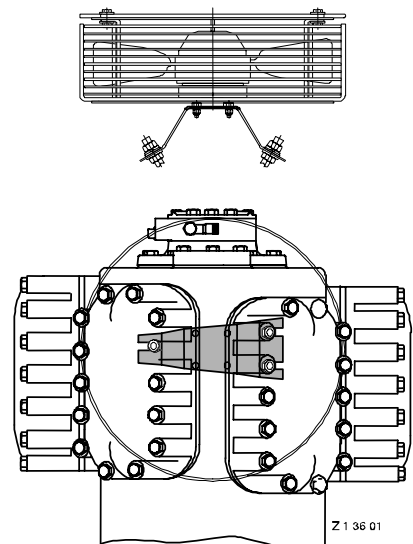

3.4 Brackets mounting and tightening torques

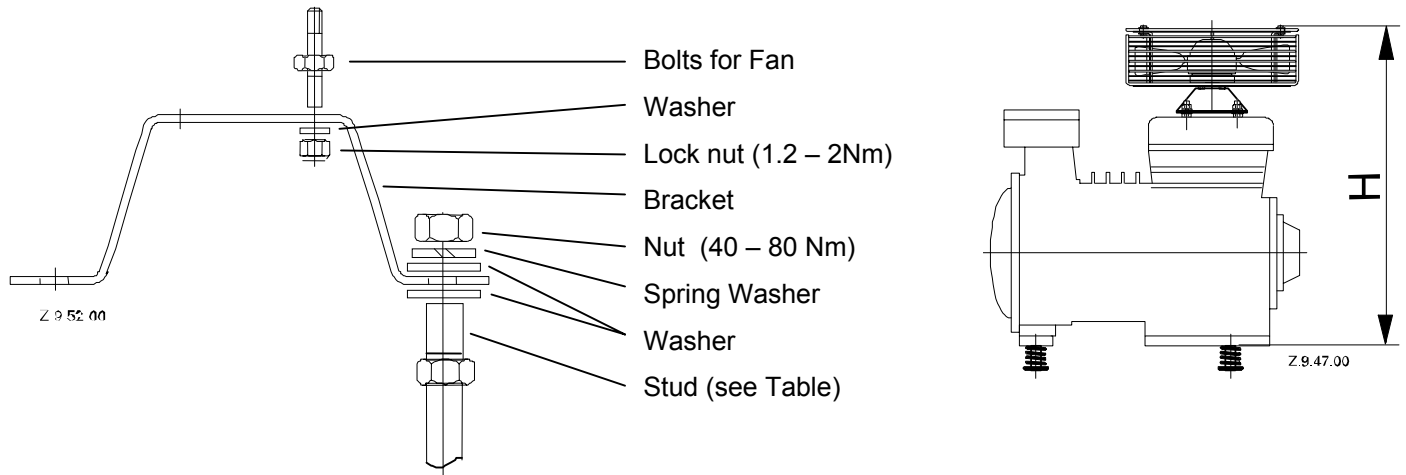

3.4.1 Tightening torques

- DL, D2S 50 - 54 Nm
- Other compressors 58 - 69 Nm

3.4.2 Dimension H

H in mm	DL	D2S	D2D	D9	D3S	D3D	D4	D6	D8
	530	530	610	615	615	625			
With capacity control						710			
Version SA/SF							530	600	
Version SH/SL/ST							530	600	660
Version SJ							545	680	665
Version SK								680	665
Version DA/DF							560	665	
Version DH/DL							560	665	660
Version DJ/T							560	715	660

Information in this document are subject to change without notification.