



iCHiLL



QUICK REFERENCE GUIDE IC200CX EVO (rel. 1.0)

INDEX

1	GENERAL WARNING	4
1.1	 PLEASE READ BEFORE USING THIS MANUAL	4
1.2	 SAFETY PRECAUTIONS	4
1.3	PRODUCT DISPOSAL (WEEE).....	5
2	USING THE QUICK REFERENCE GUIDE	5
3	IC200 CX TABLE OF THE FEATURES	6
4	USER INTERFACE	7
4.1	MEANING OF THE LEDS.....	7
4.2	DISPLAY AND ICONS.....	7
5	DISPLAY LAYOUT	8
6	OTHER DISPLAY INFORMATION	9
6.1	READ THE SET POINT VALUE	9
6.2	MODIFY THE SET POINT	9
7	KEY FUNCTION	10
7.1	KEY COMBINANTION.....	10
8	FIRST INSTALLING	11
8.1	ON BOARD CLOCK (OPTIONAL)	11
8.2	RTC SETUP	11
9	PARAMETERS PROGRAMMING WITH THE “HOT KEY 64”	11
9.1	HOW TO PROGRAM AN INSTRUMENT WITH AN ALREADY PROGRAMMED “HOT KEY” (DOWNLOAD).....	11
9.2	HOW TO COPY THE PARAMETER MAP INTO THE “HOT KEY” (UPLOAD).....	12
10	PROGRAMMING USING LOCAL USER INTERFACE	12
10.1	ENTER THE PROGRAMMING LEVEL PR1	12
10.2	ENTER THE PROGRAMMING LEVEL PR2	13
10.3	ENTER THE PROGRAMMING LEVEL PR3	13
11	MENU (MENU KEY)	13
11.1	ALARM LIST: READ AND RESET	14
11.2	ALARM LOG LIST	14
12	REMOTE KEYBOARD VICX620 EVO	15
13	REMOTE KEYBOARD V2I820	15
13.1	PROBES VISUALIZATION	17
13.2	VISUALIZZAZIONE / MODIFICA SET POINT.....	17
13.3	ALARM VISUALIZATION.....	18
14	TABLE OF THE OUTPUT STATUS IN ALARM CONDITION	19
14.1	ALARM: “A” TYPE AND STATUS OF THE LOADS IN CASE OF ALARM	19
14.2	ALARM: “B” TYPE AND STATUS OF THE LOADS IN CASE OF ALARM	21
14.3	ALARM: “C” TYPE AND STATUS OF THE LOADS IN CASE OF ALARM	22
14.1	WARNING	22
15	BLACK-OUT	23
16	WIRING CONNECTIONS	23
16.1	IC206CX CONNECTIONS	23
16.2	208CX CONNECTIONS	23
16.1	REMOTE KEYBOARD CONNECTION	24
16.2	ANALOG INPUTS NTC – PTC PROBES	26

16.3	DIGITAL INPUTS.....	27
16.4	ANALOG INPUT FOR PRESSURE TRANSDUCER PP30 (4 + 20MA SIGNAL)	28
16.5	ANALOG INPUT FOR PRESSURE RATIOMETRIC TRANSDUCER PPR30 (0 + 5V SIGNAL) 28	
16.6	PWM OUTPUT FOR CONDENSING FAN SPEED CONTROL	29
16.7	PROPORTIONAL OUTPUT FOR FAN CONDENSING CONTROL OR FOR COMPRESSOR INVERTER CONTROLLED OR FOR AUXILIARY OUTPUTS.....	29
16.8	PROPORTIONAL OUTPUT 0..10V TO CONTROL DUMPER MOTORS	30
16.9	PROPORTIONAL OUTPUTS CONFIGURED FOR AUX RELAY CONTROL.....	32
17	INSTALLING AND MOUNTING	32
17.1	PANEL CUT- OUT.....	32
17.2	VERTICAL BOARDS VI620CX PANEL CUT-OUT	33
17.1	V2I820 PANEL CUT-OUT.....	34
18	ELECTRICAL CONNECTIONS.....	34
19	TECHNICAL DATA	35

1 GENERAL WARNING

1.1 PLEASE READ BEFORE USING THIS MANUAL

- This manual is part of the product and should be kept near the instrument for easy and quick reference.
- The instrument shall not be used for purposes different from those described hereunder. It cannot be used as a safety device.
- Check the application limits before proceeding.
- Dixell Srl reserves the right to change the composition of its products, even without notice, ensuring the same and unchanged functionality.

1.2 SAFETY PRECAUTIONS

- Check the supply voltage is correct before connecting the instrument.
- Do not expose to water or moisture: use the controller only within the operating limits avoiding sudden temperature changes with high atmospheric humidity to prevent formation of condensation
- Warning: disconnect all electrical connections before any kind of maintenance.
- The instrument must not be opened.
- In case of failure or faulty operation send the instrument back to the distributor or to “Dixell S.r.l.” with a detailed description of the fault.
- Consider the maximum current which can be applied to each relay (see Technical Data).
- Ensure that the wires for probes, loads and the power supply are separated and far enough from each other, without crossing or intertwining; do not use the same electrical conduit to install high voltage cabling and low voltage cabling.
- The ground connection of the secondary coil of the transformer that powers the device can result in a bad performance; where possible, this connection should be avoided.
- Fit the probe where it is not accessible by the end user.
- In case of applications in industrial environments, the use of mains filters (our mod. FT1) in parallel with inductive loads could be useful.

- The  symbol alerts the user of non-insulated “dangerous voltage” within the product area that is sufficiently high to constitute a risk of electric shock to persons.

- The  symbol alerts the user of important operating and maintenance (assistance) instructions found in the documentation attached to the device.

1.3 PRODUCT DISPOSAL (WEEE)

With reference to Directive 2002/96/EC of the European Parliament and of the Council of 27 January 2003 and to the relative national legislation, please note that:

- There lies the obligation not to dispose of electrical and electronic waste as municipal waste but to separate the waste.
- Public or private collection points must be used to dispose of the goods in accordance with local laws. Furthermore, at the end of the product's life, it is also possible to return this to the retailer when a new purchase is made.
- This equipment may contain hazardous substances. Improper use or incorrect disposal can have adverse effects on human health and the environment.
- The symbol shown on the product or the package indicates that the product has been placed on the market after 13 August 2005 and must be disposed of as separated waste.
- Should the product be disposed of incorrectly, sanctions may be applied as stipulated in applicable local regulations regarding waste disposal.

2 USING THE QUICK REFERENCE GUIDE

In this guide, there are some general guidelines regarding the product; more details are in the full manual, to be requested from the Dixell Customer Service department.

3 IC200 CX TABLE OF THE FEATURES

CHARACTERISTICS	IC206CX	IC208CX
N° KEYS		
6	●	●
RELAYS		
6	●	
8		●
DIGITAL INPUTS		
11	Configurable	Configurable
ANALOG INPUTS		
4 NTC – PTC 2 NTC - PTC - 4÷20mA - 0 ÷ 5Volt	Configurable	Configurable
PROPORTIONAL OUTPUTS		
2 configurables (signal 0÷10V)	Configurable	Configurable
2 configurables (signal 0÷10V, PWM)	Configurable	Configurable
SERIAL OUTPUTS		
TTL with Mod-BusRtu protocol	●	●
Remote Keyboard VICX620 (up to 2 remote keyboards with probe on board)	●	●
POWER SUPPLY		
12 Vac/dc (+15%;-10%)	●	●
24 Vac/dc (± 10%)	Opt	Opt
MAIN DISPLAY (UPPER DISPLAY)		
± 4 digits with decimal point	●	●
SECONDARY DISPLAY (LOWER DISPLAY)		
± 4 digits with decimal point	●	●
OTHER		
Clock on board	Opt	Opt
Buzzer	Opt	Opt





- Opt = optional
- ● = default

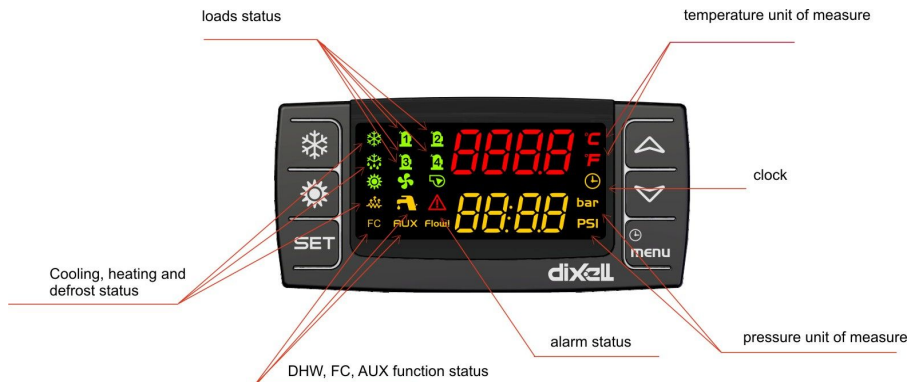



4 USER INTERFACE

4.1 MEANING OF THE LEDS



4.2 DISPLAY AND ICONS

ICON	MEANING / FUNCTIONNING
°C °F BAR PSI	Lighted when the display shows a temperature or pressure
	Lighted when the bottom display shows the clock Lighted during the programming parameters if it is time based Lighted in function menu when the display shows the defrost delay
	Alarm: blinking in case of alarm
	Lighted when sanitary hot water function is active
MENU	Lighted after pressing menu button
	Lighted if anti freeze heaters/ integration heating / boiler are activated

Flow!	Flow switch alarm / supply fan overload (air / air unit)
	Water pump: lighted if at least one pump is ON
	Condenser fan: lighted if at least one fan is ON
	Lighted when a compressor is ON Blinking = when the delay of activation is running
AUX	Lighted when auxiliary function is active
	Lighted when the controller is ON in cooling or heating
FC	Lighted when the Free cooling is active
	Lighted when the defrost is activated Blinking when the delay to activate the defrost is active

5 DISPLAY LAYOUT

Pressing Up or Down button the display shows the temperature or pressure of the main probes configured in the instrument.

The lower display shows the label of the selected probe while the upper display shows its value.

If the machine is configured with two gas circuits, when on the display is visualized the condenser pressure/temperature or evaporation pressure of circuit 1, pressing SET button the display shows condenser pressure/temperature or evaporation pressure of circuit 2.

Fig.1



Fig.2



6 OTHER DISPLAY INFORMATION

6.1 READ THE SET POINT VALUE

Press and release the SET key:

If the unit is on standby:

- lower display shows SETc (set chiller);
- press SET key again, lower display shows SETh (set heat pump, if it is enabled);
- press SET key again, lower display shows SETr (set real of operation, in the case where the Energy Saving and / or function dynamic set point are active);
- press SET key again, lower display shows SETs (set sanitary circuit, in case it is enabled)

If the instrument is in chiller operation:

- lower display shows SETc (set chiller);
- press SET key again, lower display shows SETr (set real of operation, in the case where the Energy Saving and / or function dynamic set point are active);
- press SET key again, lower display shows SETs (set sanitary circuit, in case it is enabled)







If the instrument is in chiller operation:

- lower display shows SETh (set heat pump);
- press SET key again, lower display shows SETr (set real of operation, in the case where the Energy Saving and / or function dynamic set point are active);
- press SET key again, lower display shows SETs (set sanitary circuit, in case it is enabled)

6.2 MODIFY THE SET POINT







- push **SET** key for at least **3** seconds
- use the **UP** or **DOWN** key to modify the setpoint. In chiller mode it is possible to modify the chiller set point, in heat pump it is possible to modify the heat pump set point, in std-by it is possible to modify both the set point.
- push **SET** to confirm or wait the timeout (15seconds).

7 KEY FUNCTION

KEY	ACTION	FUNCTION
	Push and release	Show chiller set point SetC , heat pump set point SetH , sanitay water set point SetS
	Push once again	In chiller or heat pump if the Energy saving or the Dynamic setpoint are enabled it shows the real setpoint Setr .
	Push for 3 seconds	Set point modification
	During the programming: push once	To enter parameter modification or confirm a value
	Push when an alarm is showed in menù ALrM	To reset the alarm
	Push once with probe label showed on the bottom display (press up or down starting from default visualization)	To read probes values of circuit 1 or circuit 2
	Push once	To read probes value
	Pushing once during the programming	To change the group of parameters, to change the parameter, to change the value of the parameter
	Push for 1 second during the programming when the display visualizes Pr1 or Pr2 or Pr3	1 time shows the Pr2 programming level 2 times shows the Pr3 programming level
	Push once	To read probes value
	Pushing once during the programming	To change the group of parameters, to change the parameter, to change the value of the parameter
	Push once	To turn ON or turn OFF the controller (in chiller or heat pump depending from CF58 parameter)
	Push once	To turn ON or turn OFF the controller (in chiller or heat pump depending from CF58 parameter)
	Push once	To enter the function Menu
	Push for 3 seconds	To set the clock (controller with clock on board)
	Pushing once during the programming	To exit from a group of parameter

7.1 KEY COMBINANTION

KEY	ACTION	FUNCTION
-----	--------	----------

 + 	Push for 3 seconds together	Enter the programming parameters
	Only in Pr3 level: push SET and DOWN key	Select the parameter level visibility Pr1 / Pr2 / Pr3
 + 	Push once together	Exit the programming parameters
	Push 5 seconds in heat pump mode	Manual defrost
 + 	Only in Pr3 programming level: push SET and then the MENU key	In Pr3 defines if the parameter can be modified or not in the other levels.

8 FIRST INSTALLING

8.1 ON BOARD CLOCK (OPTIONAL)

If giving power supply the bottom display shows “rtc” alternated to a temperature or pressure value, **It is necessary to set the RTC (Real time clock).**

The internal clock is an option of the instrument and it is not possible to update it. It is necessary to order the instrument already complete of this features.

If the instrument is disconnected to the power supply for more than 3 days, it is necessary to setup the clock.

8.2 RTC SETUP

1. Push **Menu** key continuously for 3 seconds until the bottom display shows “Hour” and the top display shows its value.
2. Push **SET** one time: the value is blinking.
3. Use the Up and Down keys to adjust it. Push **SET** one time to confirm.
4. Push up or down keys and repeat the operations 2. 3. and 4. for all the RTC parameters:
 - **Min:** minutes (0÷60)
 - **UdAy:** day of the week (**Sun** = Sunday, **Mon** =Monday, **tuE** =Tuesday, **UEd** = Wednesday, **tHu** = Thursday, **Fri** =Friday, **SAt** =Saturday)
 - **dAy:** day of the month (0÷31)
 - **MntH:** month (1÷12)
 - **yEAR:** year (00÷99)

9 PARAMETERS PROGRAMMING WITH THE “HOT KEY 64”

9.1 HOW TO PROGRAM AN INSTRUMENT WITH AN ALREADY PROGRAMMED “HOT KEY” (DOWNLOAD)

1. Power off the instrument

2. Insert the hot key already programmed (by software Wizmate or other instrument)
3. Power on the instrument
4. Automatically the parameters are downloaded

During the download the regulation is locked and the top display shows the “doL” blinking label. At the end of the download will appear:

“End” if the programming procedure is completely OK, after 30seconds the regulation starts automatically.

“Err” if the programming procedure has found an error and the parameter have not been transferred. In this case turn off and then on the instrument supply to repeat the operation or remove the hot key, with power supply off, to restart the regulation.

9.2 HOW TO COPY THE PARAMETER MAP INTO THE “HOT KEY” (UPLOAD)

1. Power on the instrument
2. Insert the hot key
3. Enter the function Menu
4. Select the **UPL** function (on the bottom display)
5. Push **SET** key and immediately the instrument starts transfer the parameters into the Hot key.

During the upload the regulation is locked and the top display shows the “UPL” blinking label. At the end of the UPLoad will appear:

“End” if the programming procedure is completely OK, after 30seconds the regulation starts automatically.

“Err” if the programming procedure has found an error and the parameter have not been transferred. Repeat the procedure.

To exit the UPL function push the MENU key or wait the time-out (15 sec).

10 PROGRAMMING USING LOCAL USER INTERFACE

Though the keyboard it is possible to modify the values of the parameters and set for each one of them the visibility and editability; each parameter can be made visible at different levels of users:

- Pr1 User level (default Password = 1)
- Pr2 Maintenance level (default Password = 2)
- Pr3 OEM level (default Password = 3)

10.1 ENTER THE PROGRAMMING LEVEL PR1

Enter the Pr1 “User level”:

1. Push **SET + DOWN** keys together for 3 seconds. The top display shows “PAS” and the bottom display shows “Pr1”.
2. Push **SET** key and the top display shows “0” blinking
3. Push **UP** or **DOWN** to select Pr1 password
4. Push **SET** and, if the value is correct, the top display shows the first family of parameters “ALL”
5. Push **UP** or **DOWN** to select the parameter family
6. Push **SET** to enter; the bottom display shows the first available parameter while the top display shows its value.
7. Push **UP** or **DOWN** to modify its value
8. Push **SET** to confirm the new value

9. If necessary, modify others parameter
10. Push **SET + UP** keys together to exit parameters programming

10.2 ENTER THE PROGRAMMING LEVEL PR2

Enter the Pr2 “service level”:

1. Push **SET + DOWN** keys together for 3 seconds. The top display shows “PAS” and the bottom display shows “Pr1”
2. Push **UP** key for 2 seconds and the top display will show Pr2
3. Push **SET** key and the top display shows “0” blinking
4. Push **UP** or **DOWN** to select Pr2 password
5. Push **SET** and, if the value is correct, the top display shows the first family of parameters “**ALL**”
6. Push **UP** or **DOWN** to select the parameter family
7. Push **SET** to enter, the bottom display shows the first available parameter label while the top display shows its value
8. Push **UP** or **DOWN** to modify its value
9. Push **SET** to confirm the new value
10. If necessary, modify others parameter
11. Push **SET + UP** keys together to exit parameters programming

10.3 ENTER THE PROGRAMMING LEVEL PR3

Enter Pr3 “OEM level”:

1. Push **SET + DOWN** keys together for 3 seconds. The top display shows PAS and the bottom display shows Pr1
2. Push **UP** key for 2 seconds and the top display shows Pr2
3. Push **UP** key again for 2 seconds and the top display will show Pr3
4. Push **SET** key and the top display shows “0” blinking
5. Push **UP** or **DOWN** to select Pr3 password
6. Push **SET** and, if the value is correct, the top display shows the first family of parameters “**ALL**”
7. Push **UP** or **DOWN** to select the parameter family
8. Push **SET** to enter; the bottom display shows the first available parameter label while the top display shows its value
9. Push **UP** or **DOWN** to modify its value
10. Push **SET** to confirm the new value
11. If necessary, modify others parameter
12. Push **SET + UP** keys together to exit parameters programming

11 MENU (MENU KEY)

Enter the menu:

- press the menu button;
- press the UP or DOWN button to select the submenu;
- press the SET to enter the submenu.

Exit menu functions:

- Press the menu button or wait the time-out.

Entering the menu, it is possible to:

1. Read and reset the alarms (**ALrM**)
2. Read and reset the alarm log (**ALOG**)
3. Upload the parameter into the Hot Key (**UPL**)
4. Enable – disable a gas circuit (**CrEn**)
5. Enable – disable a compressors (**COEn**)
6. Read and reset the number of compressor running hour (**Hour**)
7. Read and reset the number of compressor starts-up (**COSn**)
8. Read dynamic set point probe value (**PbdS**)
9. Read compressor discharge temperature (**COdt**)
10. Read condensing fan speed percentage of the proportional output (**Cond**)
11. Read the percentage of the proportional output 0 ÷ 10 Vdc **Pout**
12. Enable – disable one of the pumps **POEn**
13. Read the delay time between two defrost cycles (**dF**)
14. Read auxiliary output probe value (**uS**)
15. Read the temperature measured by internal sensor of the remote keyboards (**trEM**)
16. Read the temperature, the set point and the output status of the Free cooling (**FC**)
17. Read the temperature, the set point and the output status of the Solar panel (**SoL**)
18. Read temperature, pressure and status of the electronic expansion valve 1 (**Et1**)
19. Read temperature, pressure and status of the electronic expansion valve 2 (**Et2**)

11.1 ALARM LIST: READ AND RESET

ALrM FUNCTION

1. Push MENU key
2. The display shows ALrM label
3. Push **SET** key (Nothing happens if there are not alarms)
4. The bottom display shows the alarm code and the top display shows the label **rSt**, if it is possible to reset the alarm, or **NO** if it is not possible to reset the alarm
5. Push **UP** or **DOWN** to scroll the alarm list (if more than one alarm is active)
6. Repeat the reset procedure for each alarm
7. To exit the ALrM reset, push MENU or wait the timeout.

11.2 ALARM LOG LIST

ALOG FUNCTION

1. Push MENU key
2. Push **UP** or **DOWN** to select ALOG
3. Push SET key
4. The bottom display shows the alarm label, the top display shows a number in the range 00 to 99.
5. Use the UP or DOWN keys to scroll the list.
6. To exit the ALOG function push MENU or wait the timeout.

Erase the Alarm log list

1. Push MENU key
2. Push **UP** or **DOWN** to select ALOG
3. Push the **SET** key
4. Push **UP** or **DOWN** keys and search the **ArSt** label on the bottom display; the top display shows PAS.
5. Push **SET**; the bottom display shows **PAS** and the top display shows "0" blinking

6. Push **UP** or **DOWN** to set the password
7. If the password is OK the label **ArST** blinks for 5 seconds then the display returns to normal condition read-out
8. If the password is not correct the display shows **PAS** again
9. To exit, push the MENU key or wait the timeout.

The standard password to reset the alarm log is "4".

12 REMOTE KEYBOARD VICX620 EVO

The display visualization and the button functions are the same of the Ichill, then refer to previous chapters of the quick reference guide.













13 REMOTE KEYBOARD V2I820









The main window shows the temperature / pressure measured by the main probe of the machine.

Some icons indicate the activation of the main loads (compressors, water pumps, fans, heaters), the status of the machine (production of hot water, defrost, unloading, energy saving and alarm):

- unit status: ON/OFF status and operating mode (cooling, heating,)
- time and date, if the iCHILL 200D is equipped with on-board clock
- the value of 4 sensors can be configured as desired through the parameters dP06..dP09
- the load status

	Compressor/s (blinking during the start up delay)		Economy function
	Water pump / Supply fan		Unloading function
	Condenser fan		Economy or ON/OFF by timetable
	Electric heater		Defrost
	Sanitary water		Alarm
	Recovery enabled		

Meaning of the keys:

	Allows to read the value of the probes configured in the Ichill		Allows to read/modify the set point
	Allows to switch on the Ichill in heating or cooling mode (see parameter CF78)		Allows to read the alarms
	Allows to switch on the Ichill in heating or cooling mode (see parameter CF78)		Allows to enter the SERVICE menu
	Allows to put the Ichill in STD-BY		Allows to read the main information of the circuits (compressor status, water pump status, pressure probe value,...)

Note:
in case of alarm, press any key to silence the buzzer.

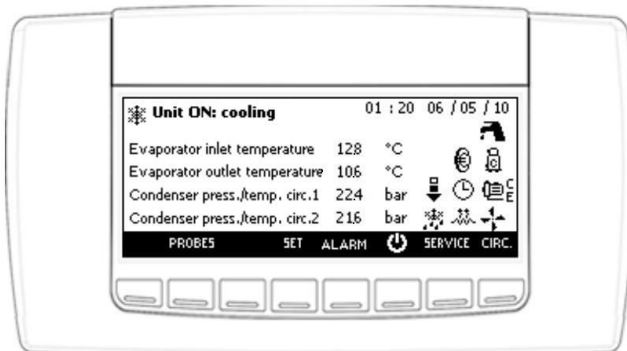

13.1 PROBES VISUALIZATION

Press **PROBES** key to visualize the value of the probes configured in the Ichill and I/O expansion (press **▲** or **▼** to visualize all the probes).

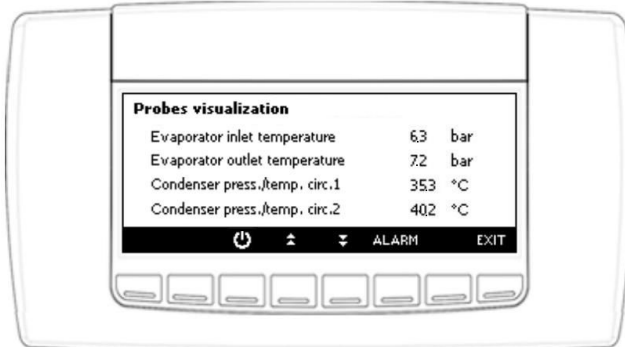

13.2 VISUALIZZAZIONE / MODIFICA SET POINT

Press **SET** key to read the value of the set point (cooling set point if the Ichill is in cooling mode, heating set point if the Ichill is in heating mode, cooling and heating set point if the Ichill is in STD_BY or remote OFF, Sanitary water when enabled).

It is also possible to read the status of the Energy saving, the status of the Dynamic set point and the real value of the set point if the Energy saving or Dynamic set point are active.

To modify the set point (Cooling, Heating or Sanitary water):

- press **▲** or **▼** to select the value of the set point
- press **SET**
- press **▲** or **▼** to modify the value
- press **SET** to confirm the operation

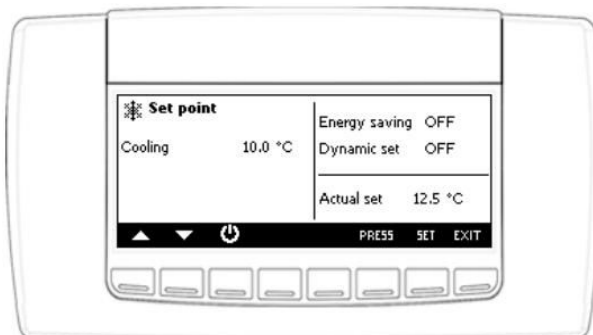

13.3 ALARM VISUALIZATION

Press **ALARM** key to read the alarm status; the alarm status can be:

- **Active:** the alarm is still active and it is not possible to reset it
- **Reset:** the alarm is not active and it is possible to reset it

Manual reset procedure:

- press **▲** or **▼** to select the alarm;
- press **RESET** to reset the alarm

In case of compressor overload alarm when the password is requested, follow this step:

- press **▲** or **▼** to select the compressor overload alarm
- press **RESET**
- press **SET**
- press **▲** or **▼** to insert the password value (parameter AL46)
- press **SET** to confirm the operation

Note:

in case of alarm, first key pressure silence internal buzzer (if enabled).

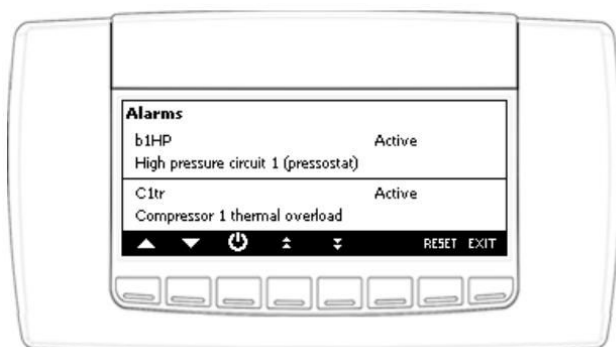

14 TABLE OF THE OUTPUT STATUS IN ALARM CONDITION

14.1 ALARM: "A" TYPE AND STATUS OF THE LOADS IN CASE OF ALARM

Alarm Code	Alarm description	Compressor	Anti freeze heaters Boiler	Support heaters	Evap. Pump. Supply fan	Condenser Pump	Cond. Fan Cir1 Cir2	Auxiliary relay
ACF1 .. ACF16	Configuration alarm	OFF	OFF	OFF	OFF	OFF	OFF	OFF
ACFL	Condenser flow alarm	OFF				OFF (3)	OFF	
AEE	Eeprom alarm	OFF			OFF	OFF	OFF	OFF
AEFL	Evaporator flow alarm	OFF	OFF (boiler)		OFF (3)		OFF	
AEht	High water temperature inlet evaporator	OFF						
AELt	Low temperature of the evaporator inlet in Heat Pump mode	OFF						
AHFL	Sanitary water pump flow alarm	OFF (6)	/	/	/	/	/	/
ALc1	Generic alarm n°1	OFF			OFF	OFF	OFF	OFF
ALc2	Generic alarm n°2 and AL56=0							
ALSF	Phase sequence alarm	OFF	OFF	OFF	OFF	OFF	OFF	OFF
ALti	Low air temperature of the evaporator inlet (air / air unit) Alarm							
Ap1 .. Ap6	Probe failure	(7)	Yes (6)	(7)	(7)	(7)	(7)	Spent o (2)
APE1 ...	I/O expansion	(7)	(7)	(7)	(7)	(7)	(7)	(7)

APE8	probes							
APFL	Solar panel water pump flow alarm	/	/	/	/	/	/	/
APr1 APr2	Remote terminals probe	(7)	(7)	(7)	(7)	(7)	(7)	(7)
APU1 ... APU4	IEV Electronic expansion valve probes	(8)	(8)	(8)	(8)	(8)	(8)	(8)
ASLA	Serial communication failure with I/O expansion	OFF	OFF	OFF	OFF	OFF	OFF	OFF
AtAS	Sanitary water pump overload	OFF (6)	/	/	/	/	/	/
AtC1	Condenser water pump 1 overload alarm	OFF (4)				OFF	OFF	
AtC2	Condenser water pump 2 overload alarm	OFF (4)				OFF	OFF	
AtE1	Evaporator water pump 1 overload alarm	OFF (4)	OFF (boiler) (5)		OFF		OFF	
AtE2	Evaporator water pump 2 overload alarm	OFF (4)	OFF (boiler) (5)		OFF		OFF	
AtHS	Sanitary heater overload	/	/	/	/	/	/	/
AtSF	Supply fan overload alarm	OFF		OFF	OFF		OFF	
AUAL	Serial communication failure with expansion valve driver	OFF	OFF	OFF	OFF	OFF	OFF	OFF
Err	Contemporary activation of cooling and heating	OFF	OFF	OFF	OFF	OFF	OFF	OFF

request on condensing unit								
----------------------------------	--	--	--	--	--	--	--	--

- (1) = if probe configured as anti-freeze / boiler control and Ar10 = 0
- (2) = if probe configured to control the auxiliary output
- (3) = if the alarm is manual reset
- (4) = compressors off if only 1 water pump configured or if 2 water pumps and both in alarm
- (5) = boiler heaters off if only 1 water pump configured or if 2 water pumps and both in alarm (in this case boiler heaters are used only for anti-freeze)
- (6) = if enabled the only sanitary water function, or if the chiller and heat pump set point are reached
- (7) = load switching off depends on the probe on error; regulation probe alarm switch off main loads, external probe alarm disable only dynamic set point function
- (8) = in case of electronic expansion valve probe alarm, all the loads of gas circuits where the valve is mounted are switched off

14.2 ALARM: “B” TYPE AND STATUS OF THE LOADS IN CASE OF ALARM

Alarm Code	Alarm description	Compressors of the circuit (n)	Compressors of the other circuit	Fan condensing of the circuit (n)	Fan condensing of the other circuit
b(n)AC	Anti-freeze in chiller circuit (n)	OFF		OFF	
b(n)Ac	Anti-freeze circuit (n) warning in chiller				
b(n)AH	Anti-freeze in heat pump circuit (n)	OFF		OFF	
b(n)Ah	Anti-freeze circuit (n) warning in heat pump				
b(n)dF	End defrost warning circuit (n)				
b(n)ds	Circuit (n) disabled from keyboard	OFF		OFF	
b(n)Eu	Unloading from evaporator low temp/press of the circuit (n)	OFF		OFF	
b(n)HP	High pressure switch circuit (n)	OFF		OFF after 60 seconds	
b(n)hP	High condensing pressure of the circuit (n)	OFF		OFF after 60 seconds	
b(n)hP	High condensing temperature from NTC of the circuit (n)	OFF		OFF after 60 seconds	
b(n)LP	Low pressure switch circuit (n)	OFF		OFF	
b(n)LP	Low condensing pressure - (evaporating with low pressure transducer) with transducer of the circuit of the	OFF		OFF	

	(n)				
b(n)IP	Low condensing temperature NTC circuit (n)	OFF		OFF	
b(n)PH	Pump down alarm in stop regulation of the circuit (n)	OFF		OFF	
b(n)PL	Pump down in regulation start-up of the circuit (n)	OFF		OFF	
b(n)rC	Recovery function disabled in circuit (n)				
b(n)tF	Fan overload circuit (n)	OFF		OFF	
b(n)UA	IEV electronic expansion valve driver alarm circuit (n)	OFF	/	OFF	/

(n) identifies the circuit 1 or 2

14.3 ALARM: “C” TYPE AND STATUS OF THE LOADS IN CASE OF ALARM

Alarm Code	Alarm description	Compressor (n)	Compressors not involved
C(n)dS	Compressor (n) disabled from keyboard	OFF	
C(n)dt	Compressor high discharge temperature	OFF	
C(n)HP	Compressor(n) high pressure switch	OFF	
C(n)Mn	Compressor(n) maintenance		
C(n)oP	Compressor(n) oil pressure switch / Oil level switch	OFF	
C(n)tr	Compressor(n) overload	OFF	

(n) identifies the compressor 1, 2, 3, 4

14.1 WARNING

Alarm Code	Alarm description
ACP1	Condenser water pump 1 maintenance
ACP2	Condenser water pump 2 maintenance
AEP1	Evaporator water pump 1 maintenance
AEP2	Evaporator water pump 2 maintenance
AEUn	Unloading caused by evaporator high temp.
ArtC	Clock setting
ArtF	Clock failure
ASAn	Sanitary water pump maintenance
ASun	Solar panel water pump maintenance
Atr1	Remote terminal n° 1 configured but not connected
Atr2	Remote terminal n° 2 configured but not connected
b(n)Cu	Unloading caused by condenser high temp/press circuit (n)
b(n)Eu	Unloading from evaporator low temp/press of the circuit (n)
noL	Communication problem with Ichill and remote keyboard

15 BLACK-OUT

After the black-out, when the power supply is restored:

1. the instrument restores the same operating mode lost after the supply failure.
2. if active at the power off, the defrost is aborted
3. All the timers are reloaded
4. The alarm, if actives in manual mode at the power down, is not reset

16 WIRING CONNECTIONS

16.1 IC206CX CONNECTIONS

- 6 digital outputs (relays)
 - MAX. current on the relay contacts 5(2)A 250V
 - MAX. Current on the coomon line (C1R and, C2R) 10A 250V
- 11 digital inputs (free of voltage)
- 6 analogue inputs:
 - 4 NTC / PTC probes
 - 2 NTC / PTC / pressure transducer 4÷20 mA / pressure transducer ratio-metric 0÷ 5Volt
- 4 modulating outputs:
 - 2 0 ÷ 10 Volt
 - 2 0 ÷ 10.0 Volt or cut of phase (for modulating condenser fan)
- 1 LAN output to connect the I/O expansion and IEV electronic expansion valve
- 1 output to connect a remote keyboard (max. 2 VICX620 EVO or 1 VGI820)
- 1 TTL output for "Hot Key 64" or for XJ485CX (interface module for monitoring system)

C1R = common line for RL1, RL2, RL3, RL4

C2R = common line for RL5, RL6

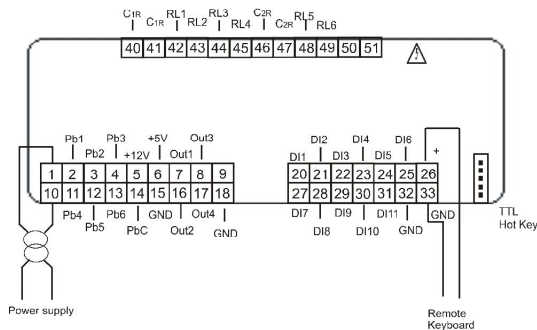

16.2 208CX CONNECTIONS

- 8 digital outputs (relays)
 - MAX. current on the relay contacts 5(2)A 250V
 - MAX. Current on the common line (C1R and, C2R) 10A 250V
- 11 digital inputs (free of voltage)
- 6 analogue inputs:
 - 4 NTC / PTC probes
 - 2 NTC / PTC / pressure transducer 4÷20 mA / pressure transducer ratio-metric 0÷ 5Volt
- 4 modulating outputs:
 - 2 0 ÷ 10 Volt
 - 2 0 ÷ 10.0 Volt or cut of phase (for modulating condenser fan)
- 1 LAN output to connect the I/O expansion and IEV electronic expansion valve
- 1 output to connect a remote keyboard (max. 2 VICX620 EVO or 1 V2I820)
- 1 TTL output for "Hot Key 64" or for XJ485CX (interface module for monitoring system)

C1R = common line for RL1, RL2, RL3, RL4

C2R = common line for RL5, RL6, RL7, RL8

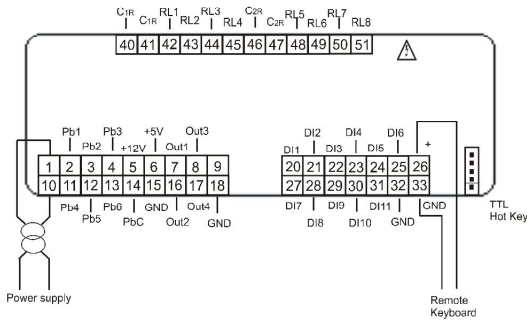

16.1 REMOTE KEYBOARD CONNECTION

It is possible to connect to the instrument up to two remote terminals VICX620 EVO, available with / without temperature probe on board, or an LCD keyboard Visograph 2.0 (V2I820 without probes on board); the use of keyboards VICX620 EVO exclude the possibility of use of the keyboard Visograph and vice versa.

If the remote terminal VICX620 EVO is provided with temperature sensor on board, the temperature adjustment can be performed with the probe at the edge of the terminal.

To enable the remote keyboard is necessary to configure the following parameters (in the Ichill parameter map):

- CF54 Enable remote terminal 1 (VICX620 EVO)
- CF55 Enable remote terminal 2 (VICX620 EVO)
- CF84 Enable remote terminal Visograph (V2I820)

The connection of the remote terminals must be performed using a shielded / twisted (such as Belden 8772, wires 1 mm² minimum); the maximum cable length to connect the keyboard VICX 620 is 100 mt (maximum length of the connection, both if using one or two keyboards), and the maximum cable length to connect the keyboard Visograph is 60 mt.

In case of lack of communication between the device and the keyboard (wrong connection, wrong configuration parameters), the display shows the message "noL" (no link).

When using two keyboards VICX620 EVO you must configure the dip switches on the rear of the same, giving to the first keyboard address 1 and to the second keyboard address 2.

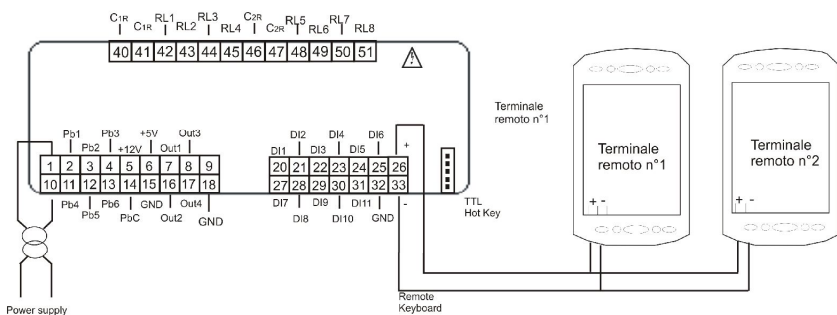
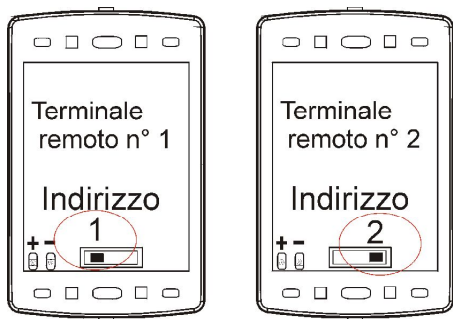

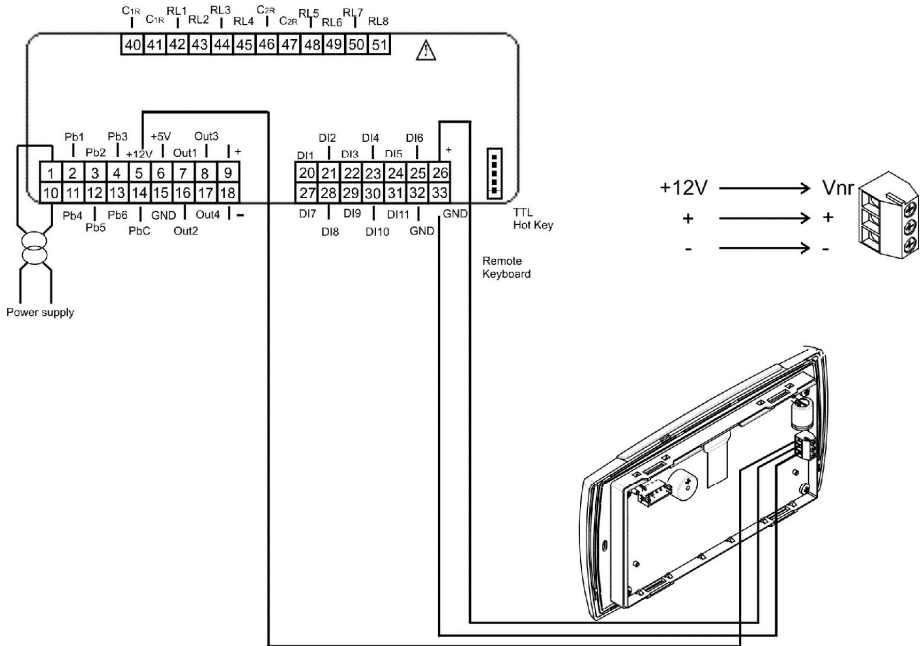

16.2 ANALOG INPUTS NTC – PTC PROBES

PbC = common terminal
Pb1...Pb6 = probe inputs

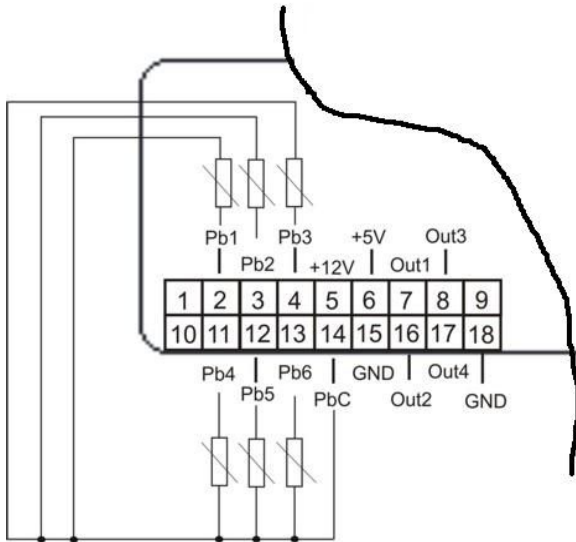

16.3 DIGITAL INPUTS

GND = common terminal
ID1...ID11 = digital inputs

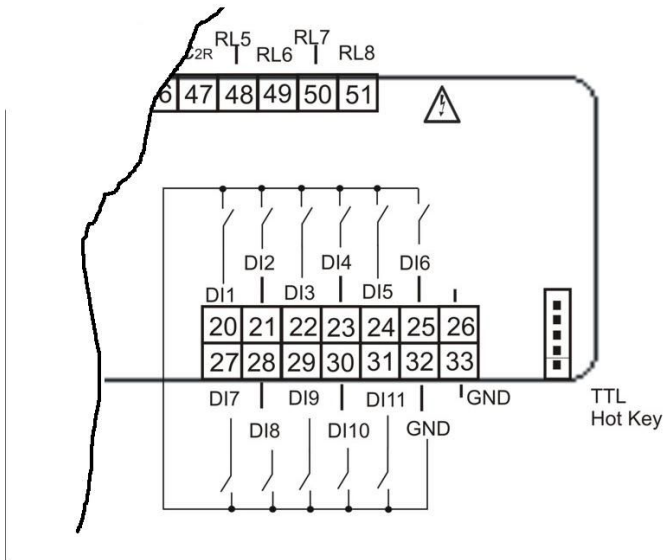

16.4 ANALOG INPUT FOR PRESSURE TRANSDUCER PP30 (4 ÷ 20mA SIGNAL)

12V = power supply for pressure transducers
Pb3 and Pb4 = pressure transducer inputs

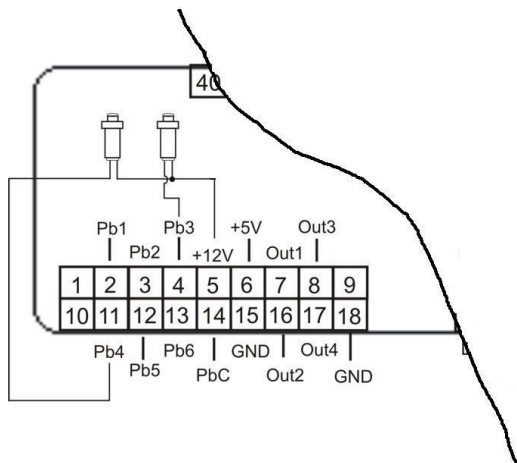

16.5 ANALOG INPUT FOR PRESSURE RATIO METRIC TRANSDUCER PPR30 (0 ÷ 5V SIGNAL)

+5V = power supply for pressure transducers
GND = ground for pressure transducers
Pb3 and Pb4 = pressure transducer inputs

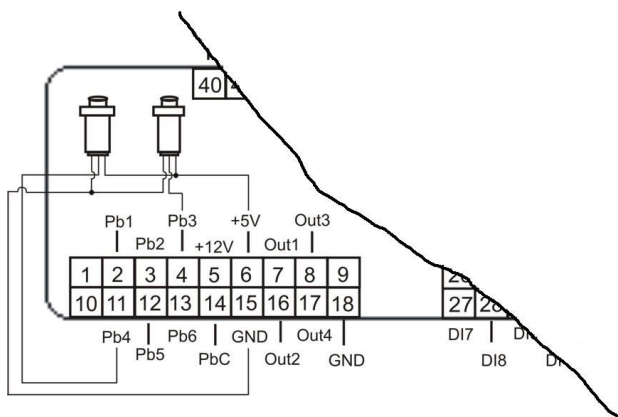

16.6 PWM OUTPUT FOR CONDENSING FAN SPEED CONTROL

OUT3 and OUT4 = signals for the modulation of the condenser fan
GND = ground for pressure transducers

The compatible modules are the following:

XV05PK mono-phase 500 Watt (2A)

XV10PK mono-phase 1000 Watt (4A)

XV22PK mono-phase 2200 Watt (9A)

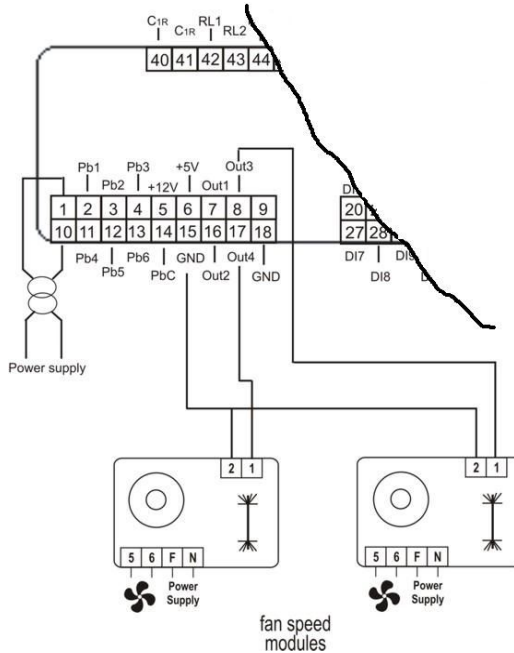

16.7 PROPORTIONAL OUTPUT FOR FAN CONDENSING CONTROL OR FOR COMPRESSOR INVERTER CONTROLLED OR FOR AUXILIARY OUTPUTS

OUT1...OUT4 = signals for the modulation of the condenser fan
GND = ground for pressure transducers

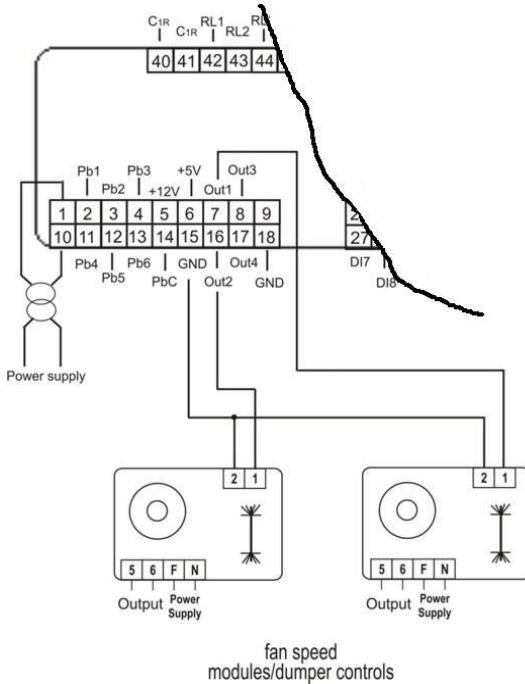

16.8 PROPORTIONAL OUTPUT 0..10V TO CONTROL DUMPER MOTORS

OUT1...OUT4 = signals for the modulation of the dumper motor

GND = ground

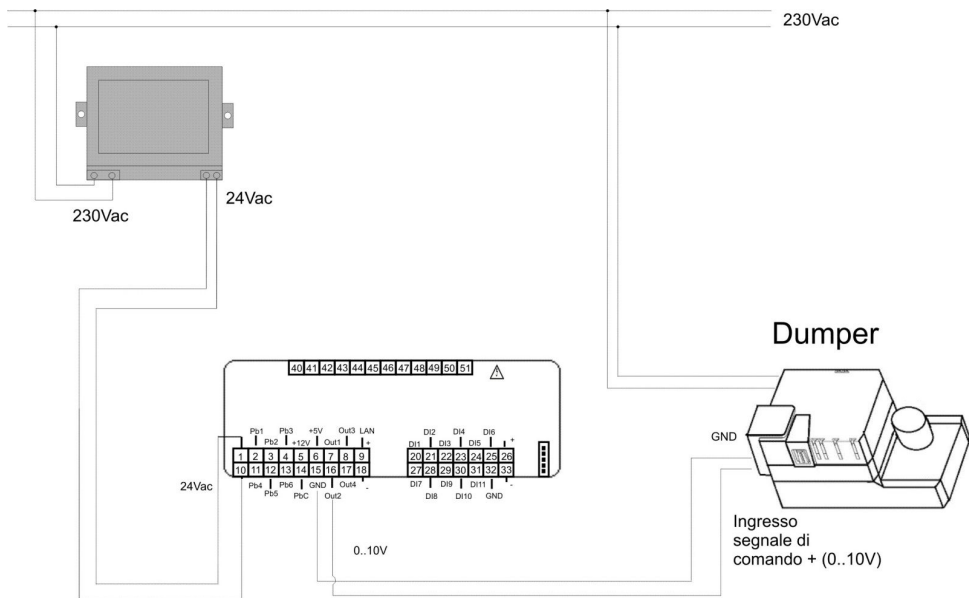

If the dumper motor has a common line between a pole of the power supply and the “-” pole of the 0..10V signal, it is necessary to use two transformers for the power supply of the controller iChill and the power supply of the dumper motor.

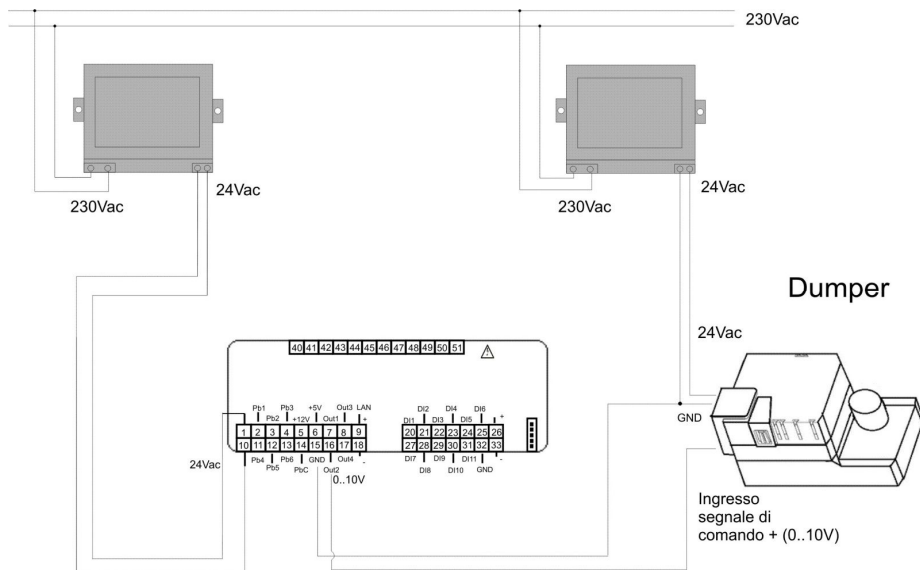

16.9 PROPORTIONAL OUTPUTS CONFIGURED FOR AUX RELAY CONTROL

OUT1...OUT4 = signals for relays
GND = ground

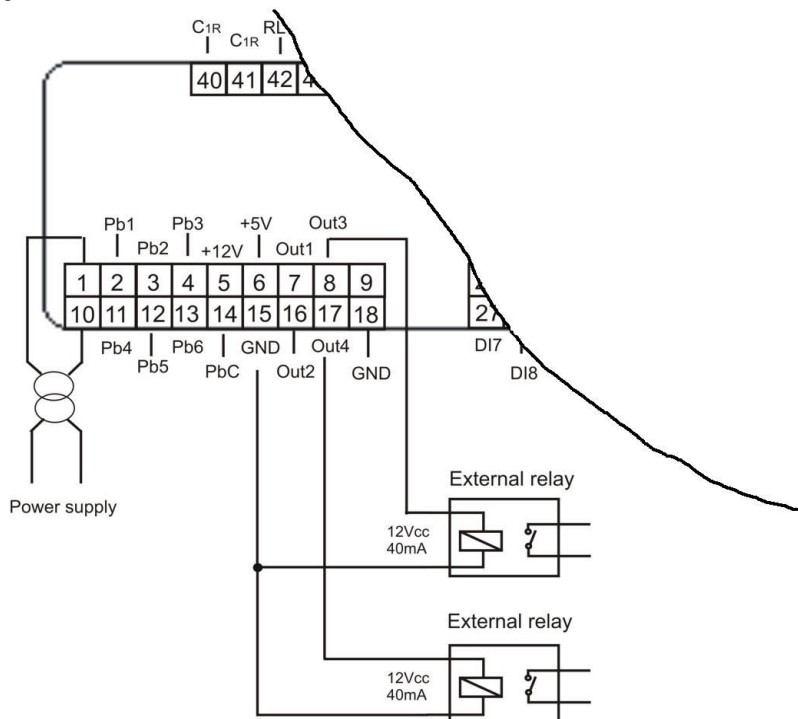

17 INSTALLING AND MOUNTING

17.1 PANEL CUT-OUT

The instrument must be mounted on vertical panel with cut-out 71x29mm, and fixed using the special supplied bracket.

Avoid locations subject to heavy vibration, corrosive gases or excessive dirt. Ensure ventilation around the instrument.

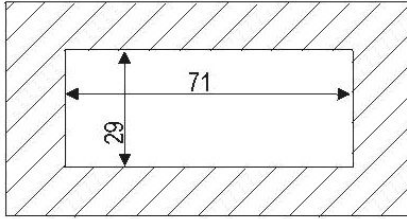

17.2 VERTICAL BOARDS VI620CX PANEL CUT-OUT

The keyboard must be mounted on vertical panel with cut-out 72x56 mm, and screwed with two screws.

The IP65 can be reached with the gasket RGW-V (optional).

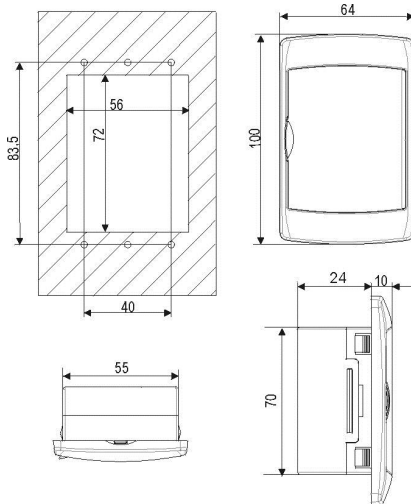

WALL MOUNTING: use the vertical V-KIT (black, white and grey) as described in the following scheme:

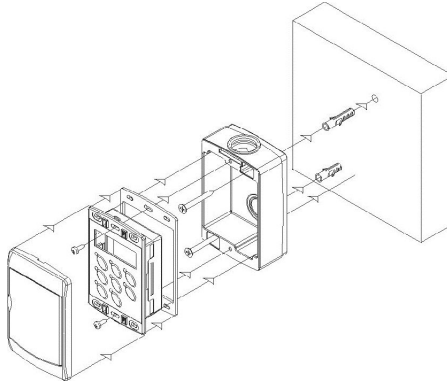

17.1 V2I820 PANEL CUT-OUT

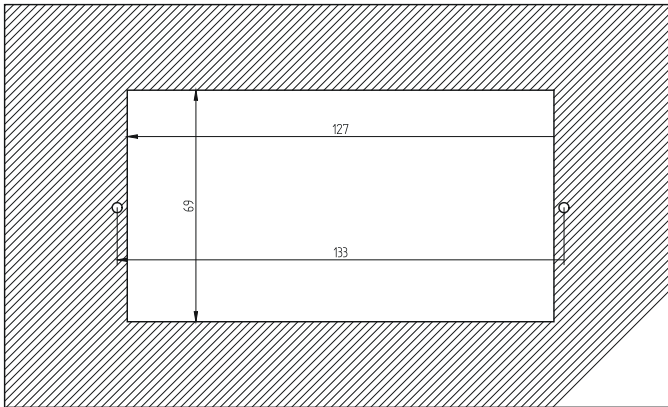

18 ELECTRICAL CONNECTIONS

The instrument is provided with:

- 2 removable terminal blocks MOLEX MICROFIT 14 and 18 ways for power supply / digital and analogue inputs and modulating outputs
- 1 removable terminal blocks AMP 12 ways for the relay outputs
- 5 ways connector for TTL RS485 interface outputs.

Wire size:

- signal cable AWG 24
- power supply cable AWG 22

- relay output AWG 17

General notes:

- Keep low voltage cables, such as analogue/digital inputs/outputs and probes, away from power cables.
- Respect the minimum load current of each relay output, in case of power loads use filtered contactors.

19 TECHNICAL DATA

Material: Housing PC + ABS, frontal panel PC

Case: 32x74 mm; depth 60mm

Mounting: panel mounting in a 29x71mm panel cut-out

Frontal protection: IP65

Power supply:

12Vac -10%+15% or

24 Vac/dc $\pm 10\%$ 50/60 Hz

Power consumption: 10VA max.

Analog Inputs:

4 configurable (NTC/PTC/dig. input)

2 configurable (NTC/PTC/4 ± 20 ma/0 ± 5 Volt/dig. input)

Digital inputs: 11 (free voltage, don't supply voltage)

Relay outputs:

IC206CX: 6 relays SPDT 5(2) A, 250Vac

IC208CX: 8 relays SPDT 5(2) A, 250Vac

Max. current on common line: 10A

Data storing: on the non-volatile memory (EEPROM).

Operating temperature: -10 ± 55 °C

Storage temperature: -30 ± 85 °C

Relative humidity: 20 $\pm 85\%$ (not condensing)

Measuring range:

- 50 ± 110 °C / - 58 ± 230 °F

-50.0 ± 150 °C / -58 ± 302 °F

0 ± 50 bar / 0 ± 725 psi

NTC probes

PTC probes

4..20mA and 0..5V probes

Resolution: 0,1 °C or 1 °F

Dixell[™]

EMERSON[™]

Dixell S.r.l. - Z.I. Via dell'Industria, 27 - 32016 Alpagò (BL) ITALY
Tel. +39.0437.9833 r.a. - Fax +39.0437.989313 - EmersonClimate.com/Dixell - dixell@emerson.com