

# **Comfort Alert<sup>®</sup>**

## **Diagnostics**

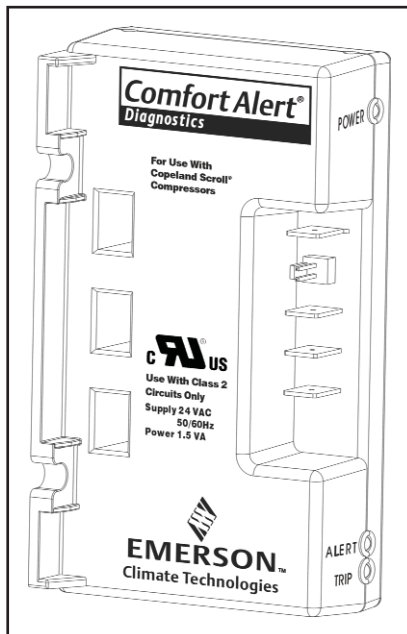

## **User's Manual**

Questions or Comments?  
Call 1-888-923-2323



**EMERSON<sup>™</sup>**  
Climate Technologies

## Comfort Alert® Diagnostics – Faster Service And Improved Accuracy

Comfort Alert is a breakthrough innovation for troubleshooting heat pump and air conditioning system failures. The module easily installs in the electrical box of the outdoor unit near the compressor contactor. By monitoring and analyzing data from the Copeland Scroll® compressor and the thermostat demand, Comfort Alert can accurately detect the cause of electrical and system related failures without any sensors. A flashing LED indicator communicates the ALERT code and guides the service technician more quickly and accurately to the root cause of a problem. The Comfort Alert module is also compatible with all Emerson branded thermostats of the 1F9X and 1F8X families that offer diagnostic “L” terminal connection. For better protection, the 1F9X/1F8X “CA” model thermostats will flash Comfort Alert codes on their display and allow active protection that turns off the compressor if a potentially harmful fault code is detected.

Comfort Alert is designed for systems with Copeland Scroll® compressors that have internal overload protection. The software in the Comfort Alert module has been optimized for different types of air conditioning applications: cooling only, heat pump, two-stage compressors, and commercial three-phase.

This user manual is for single-phase applications. For three-phase applications refer to the Comfort Alert Commercial user manual (2005ECT-191).

**NOTE:** *This module does not provide safety protection! Comfort Alert is a monitoring device and cannot control or shut down other devices.*

### LED Description (Figure 1)

**POWER LED (Green):** indicates voltage is present at the power connection of the module.

**ALERT LED (Yellow):** communicates an abnormal system condition through a unique flash code. The ALERT LED will flash a number of times consecutively, pause and then repeat the process. The number of consecutive flashes, defined as the Flash Code, correlates to a particular abnormal condition. Detailed descriptions of specific ALERT Flash Codes are shown in two tables on pages 10, 11, and 12 of this manual.

**TRIP LED (Red):** indicates there is a demand signal from the thermostat but no current to the compressor is detected by Comfort Alert. The TRIP LED typically indicates the compressor protector is open or may indicate missing supply power to the compressor.

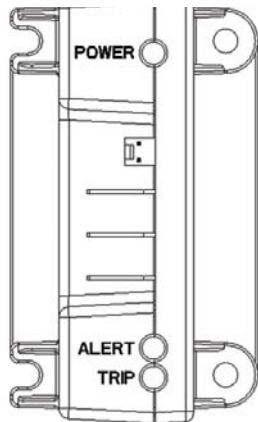

**Figure 1**  
543-0010-00  
943-0010-00



Application, Benefits And Product Specifications				
<b>Part Number: (Service Number)</b>	543-0010-00 543-0010-01 (943-0010-00) (943-0010-01)	543-0012-00 (943-0012-00)	543-0032-00	543-0033-02 (943-0033-00)
<b>Application</b>	A/C: Single Stage with Copeland Scroll®	Heat Pump: Single Stage with Copeland Scroll®	A/C and Heat Pump: Single Stage with Copeland Scroll®	A/C and Heat Pump: Two Stage with Copeland Scroll® UltraTech
<b>Benefits</b>				
Diagnostic Alert Codes	✓	✓	✓	✓
Trip Indicator	✓	✓	✓	✓
Data Port	✓	✓	✓	✓
L-Terminal Communication			✓	✓
2 Stage Solenoid Control				✓
<b>Product Specifications</b>				
Operating Temperature	-40° to 150° F (-40° to 65° C)	-40° to 150° F (-40° to 65° C)	-40° to 150° F (-40° to 65° C)	-40° to 150° F (-40° to 65° C)
Storage Temperature	-40° to 175° F (-40° to 80° C)	-40° to 175° F (-40° to 80° C)	-40° to 175° F (-40° to 80° C)	-40° to 175° F (-40° to 80° C)
Power Supply Range	19-28VAC, 48-62 Hz	19-28VAC, 48-62 Hz	18-30VAC, 48-62 Hz	18-30VAC, 48-62 Hz
Power Requirement	0.5 VA nominal	0.5 VA nominal	1.5 VA nominal	1.5VA nominal (without solenoid on) 7.0VA nominal (with solenoid on)
UL Restrictions	Use only with Class 2 circuits	Use only with Class 2 circuits	Use only with Class 2 circuits	Use only with Class 2 circuits



**WARNING**

**Hazardous voltage inside air conditioning system. Disconnect power before installing or servicing module. Module must be installed and serviced only by qualified personnel.**

### Hardware Installation

Four #8 or (#10 for part # -0032 and -0033) self drilling or sheet metal screws, at least ½” length, are required for installation of Comfort Alert. The maximum screw torque is 20 in.-lbs. Locate Comfort Alert near the compressor contactor (wire routing for compressor run, common and start wires will be easier in this position). Mount Comfort Alert so all LEDs are visible from a comfortable viewing position. The module will operate in any mounting orientation. For ease of reading labels, the module should be oriented so that the green POWER LED is at the top. **See Figures 2, 3 and 4.**

**Part Numbers: 543-0010-00, 943-0010-00,  
543-0012-00, 943-0012-00**

- A. 1.81 in (46 mm)
- B. 2.44 in (62 mm)
- C. 1.43 in (36 mm)
- D. 3.15 in (80mm)
- E. 2.44 in (62 mm)

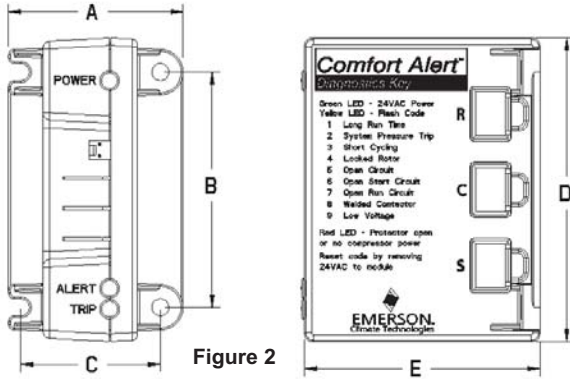

Figure 2

**Part Numbers: 543-0010-01, 943-0010-01**

- A. 1.81 in (46 mm)
- B. 2.44 in (62 mm)
- C. 1.43 in (36 mm)
- D. 3.15 in (80mm)
- E. 2.44 in (62 mm)

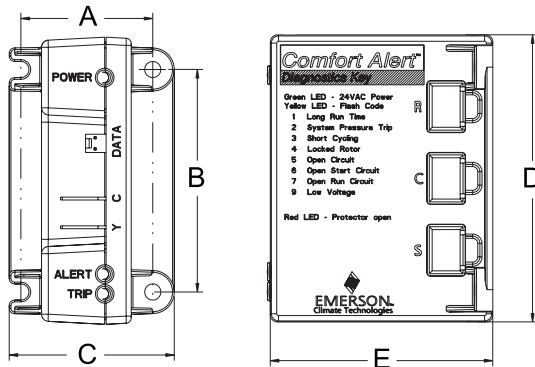
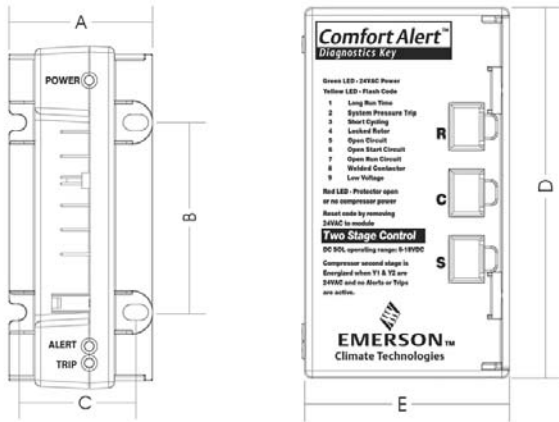

Figure 3

**Part Numbers: 543-0032-00, 943-0033-00, 543-0033-02**

- A. 1.85 in (47 mm)
- B. 2.44 in (62 mm)
- C. 1.46 in (37 mm)
- D. 4.40 in (112mm)
- E. 2.44 in (62 mm)



**Figure 4**

### Compressor Wire Routing (Figure 5)

The scroll compressor's run (R), common (C) and start (S) wires are routed through the holes in Comfort Alert marked "R," "C" and "S." The common (C) wire need not be routed through the module for it to operate properly.

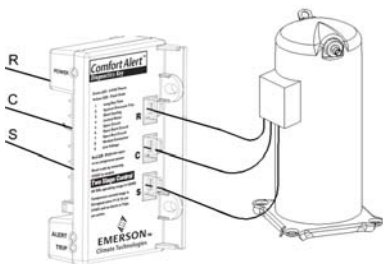

**Figure 5**

Copeland Scroll®  
Compressor

### 24VAC Power Wiring

**(except 543-0010-01, 943-0010-01)**

Comfort Alert requires a constant nominal 24VAC power supply. The wiring to the module's R and C terminals must be directly from the indoor unit or thermostat. The module cannot be powered by the C terminal on a defrost board or other control board without experiencing nuisance alerts. Refer to Figures 6 thru 10.

When constant 24VAC (R wire) is not present in the outdoor unit, use one of the spare wires in the thermostat cable to bring power to the module. Connect the other end of the spare wire to R at the indoor unit or thermostat. Refer to wiring schematic in Figures 6 thru 10.

**Note: 24VAC power wiring is not required for 2 wire Comfort Alert, which is powered by the demand (Y terminal). Even if the 24VAC power supply is available it should not be connected. Refer to Figure 7.**

### Thermostat Demand Wiring

Comfort Alert requires a thermostat demand signal to operate properly. The thermostat demand signal input, labeled Y on the module, should always be connected to the compressor contactor coil so that when the coil is energized, the demand signal input is 24VAC. When thermostat demand is not present, Y should be less than 0.5VAC.

**NOTE: Factory installed modules may have different thermostat demand signal wiring. Follow manufacturer's wiring instructions when replacing module.**

**NOTE: After the thermostat demand signal is connected, verify R and C are phased properly by measuring 24VAC across Y and C when demand is present (except 543-0010-01, 943-0010-01).**

**Figure 6: Air Conditioning Schematic 543-0010-00, 943-0010-00**

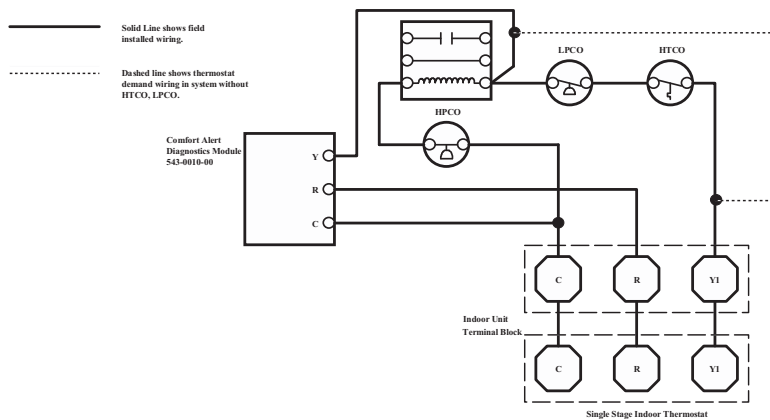

Schematic Abbreviation Description  
 HTCO High Temperature Cut Out Switch  
 HPCO High Pressure Cutout Switch  
 LPCO Low Pressure Cut Out Switch  
 CC Compressor Contactor

**Figure 7: Air Conditioning Schematic 543-0010-01, 943-0010-01**

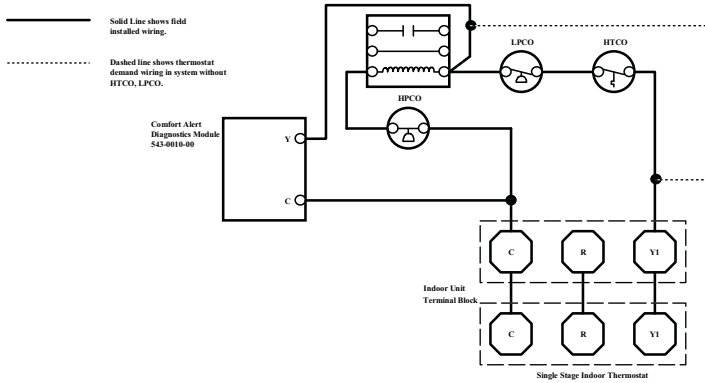

Schematic Abbreviation Description

HTCO High Temperature Cut Out Switch	CC Compressor Contactor
HPCO High Pressure Cutout Switch	
LPCO Low Pressure Cut Out Switch	

**Figure 8: Heat Pump Schematic 543-0012-00, 943-0012-00**

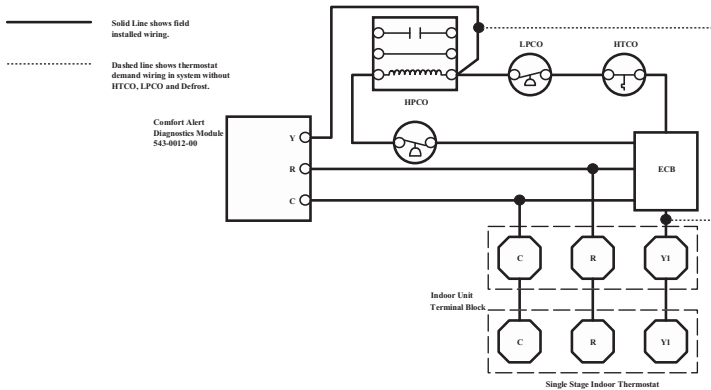

Schematic Abbreviation Description

HTCO High Temperature Cut Out Switch	CC Compressor Contactor
HPCO High Pressure Cutout Switch	ECB Electronic Control Board (Defrost Board)
LPCO Low Pressure Cut Out Switch	



**Hazardous voltage inside air conditioning system. Disconnect power before installing or servicing module. Module must be installed and serviced only by qualified personnel.**

**Figure 9: Air Conditioning or Heat Pump Schematic 543-0032-00**

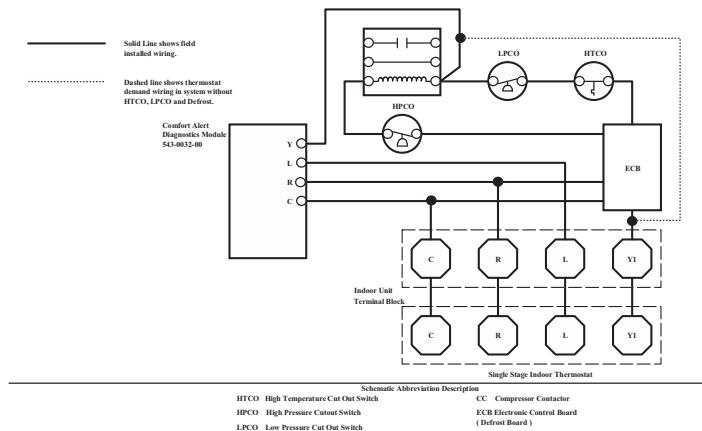

**Figure 10: Air Conditioning or Heat Pump Schematic 543-0033-02, 943-0033-00**

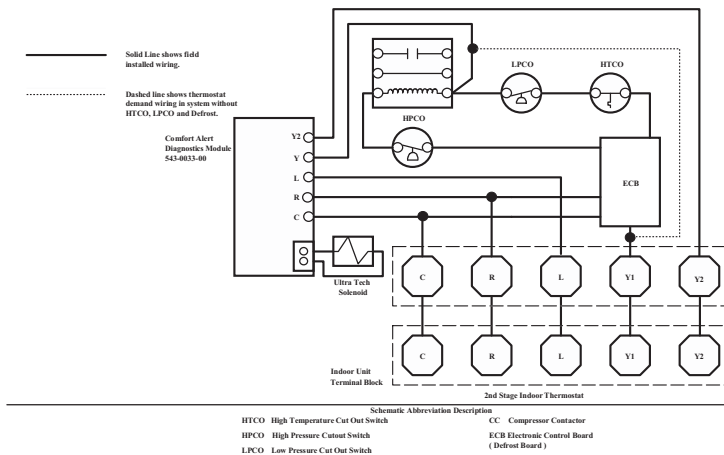

**Hazardous voltage inside air conditioning system. Disconnect power before installing or servicing module. Module must be installed and serviced only by qualified personnel.**



### **L Terminal Wiring (Part Numbers 543-0032-00, 543-0033-02, 943-0033-00)**

The L connection is used to communicate Alert codes to compatible White-Rodgers® thermostats. The L terminal of the thermostat should be connected directly to the Comfort Alert L terminal.

On select White-Rodgers thermostats, an icon on the thermostat display will flash at the same rate as the Comfort Alert yellow Alert LED. An advanced option on these thermostats is to lock out the compressor when certain Alert codes are detected indicating impending compressor damage. Refer to White-Rodgers thermostat manuals for more information.

### **Thermostat Second Stage Cooling Wiring (Part Number 543-0033-02, 943-0033-00)**

This Comfort Alert model is designed for two-stage, Copeland Scroll® UltraTech™ compressor applications and requires a two-stage thermostat to operate properly. The Y2 thermostat wire coming into the outdoor unit should be connected to the Y2 input on Comfort Alert.

While the two-stage scroll compressor is running, Comfort Alert will provide power to the second stage cooling solenoid inside the compressor after Y2 has been energized for 5 seconds. Whenever the compressor is not running, Comfort Alert will not power the solenoid, regardless of the state of Y2. If Alert codes 1 or 9 appear while the compressor is running, Comfort Alert will turn off the solenoid to prevent solenoid damage from overheating conditions, allowing the compressor to continue to operate in part load.

### **DC SOL Connection (Part Number 543-0033-02, 943-0033-00)**

The two-pin DC SOL connector provides a connection to the Copeland Scroll UltraTech second-stage compressor solenoid. This solenoid is internal to the compressor. This 24VDC solenoid will not operate properly if 24VAC is applied directly to the compressor solenoid terminals.

To reduce the VA load of the solenoid on the system, Comfort Alert uses a phase control method to reduce the DC voltage to the solenoid to the minimum level required to keep the solenoid pulled in. As the 24VAC supply voltage varies, Comfort Alert intelligently changes the solenoid DC voltage supply to minimize power consumption. A voltmeter attached to the DC SOL output will measure 4-18VDC, when the solenoid should be energized, depending on the level of the 24VAC supply.

## Interpreting The Diagnostic LEDs

When an abnormal system condition occurs, the Comfort Alert module displays the appropriate ALERT and/or TRIP LED. The yellow ALERT LED will flash a number of times consecutively, pause and then repeat the process. To identify a Flash Code number, count the number of consecutive flashes. Every time the module powers up, the last ALERT Flash Code that occurred prior to shut down is displayed for one minute.

## Installation Check

To verify the installation of Comfort Alert is correct, two functional tests can be performed. Disconnect power from the compressor and force a thermostat call for cooling. The red Trip LED should turn on indicating a compressor trip as long as 24VAC is measured at the Y terminal. If the red LED does not function as described, refer to **Table 1** to verify the wiring.

For all models (except for 543-0010-01, 943-0010-01), the second functional test can be performed. Disconnect power from the compressor and 24VAC from Comfort Alert. Remove the wire from the Y terminal of Comfort Alert, reapply 24VAC power to Comfort Alert and reconnect power to the compressor. Force a thermostat call for cooling and when the compressor starts to run, the yellow Alert LED will begin flashing a Code 8 indicating a Welded Contactor. Disconnect power from the compressor and 24VAC from Comfort Alert. While Comfort Alert is off, reattach the wire to the Y terminal. Reapply power to compressor and 24VAC to Comfort Alert, the yellow Alert LED will flash the previous code 8 for 1 minute and then turn off. If the yellow LED does not function as described, refer to **Table 1** to verify the wiring.

## Troubleshooting The Installation

Depending on the system configuration, some ALERT Flash codes may not be active. The presence of safety switches affects how the system alerts are displayed by this module. Refer to **Figures 6 thru 10** for safety switch wiring.

## Resetting Alert Codes

Alert codes can be reset manually and automatically. The manual method to reset an Alert code is to cycle the power to Comfort Alert off and on. For automatic reset, Comfort Alert continues to monitor the compressor and system after an Alert is detected. If conditions return to normal, the Alert code is turned off automatically. Note: After power on reset, the prior alert code will flash for 60 seconds.

**Note: For 543-0010-01 and 943-0010-01 auto-reset is the only option available for resetting alert codes.**

## LED Troubleshooting Information

Status LED	Status LED Description	Status LED Troubleshooting Information
<b>Green "POWER"</b>	Module has power	Supply voltage is present at module terminals
<b>Red "TRIP"</b>	Thermostat demand signal Y is present, but the compressor is not running	<ol style="list-style-type: none"> <li>1. Compressor protector is open <ul style="list-style-type: none"> <li>• Check for high head pressure</li> <li>• Check compressor supply voltage</li> </ul> </li> <li>2. Outdoor unit power disconnect is open</li> <li>3. Compressor circuit breaker or fuse(s) is open</li> <li>4. Broken wire or connector is not making contact</li> <li>5. High pressure switch open if present in system</li> <li>6. Compressor contactor has failed open</li> </ol>
<b>Yellow "ALERT" Flash Code 1</b>	<b>Long Run Time Low Refrigerant Charge</b> Compressor is running extremely long run cycles	<ol style="list-style-type: none"> <li>1. Low refrigerant charge</li> <li>2. Evaporator blower is not running <ul style="list-style-type: none"> <li>• Check blower relay coil and contacts</li> <li>• Check blower motor capacitor</li> <li>• Check blower motor for failure or blockage</li> <li>• Check evaporator blower wiring and connectors</li> <li>• Check indoor blower control board</li> <li>• Check thermostat wiring for open circuit</li> </ul> </li> <li>3. Evaporator coil is frozen <ul style="list-style-type: none"> <li>• Check for low suction pressure</li> <li>• Check for excessively low thermostat setting</li> <li>• Check evaporator airflow (coil blockages or return air filter)</li> <li>• Check ductwork or registers for blockage</li> </ul> </li> <li>4. Faulty metering device <ul style="list-style-type: none"> <li>• Check TXV bulb installation (size, location and contact)</li> <li>• Check if TXV/ fixed orifice is stuck closed or defective</li> </ul> </li> <li>5. Condenser coil is dirty</li> <li>6. Liquid line restriction (filter drier blocked if present in system)</li> <li>7. Thermostat is malfunctioning <ul style="list-style-type: none"> <li>• Check thermostat sub-base or wiring for short circuit</li> <li>• Check thermostat installation (location, level)</li> </ul> </li> <li>8. Compressor Second Stage Cooling Wiring (Except Part # 543-0012-00) <ul style="list-style-type: none"> <li>• Solenoid plug not connected</li> <li>• Y2 not wired</li> </ul> </li> </ol>
<b>Yellow "ALERT" Flash Code 2</b>	<b>System Pressure Trip High Refrigerant Charge</b> Discharge pressure out of limits or compressor overloaded	<ol style="list-style-type: none"> <li>1. High head pressure <ul style="list-style-type: none"> <li>• Check high pressure switch if present in system</li> <li>• Check if system is overcharged with refrigerant</li> <li>• Check for non-condensable in system</li> </ul> </li> <li>2. Condenser coil poor air circulation (dirty, blocked, damaged)</li> <li>3. Condenser fan is not running <ul style="list-style-type: none"> <li>• Check fan capacitor</li> <li>• Check fan wiring and connectors</li> <li>• Check fan motor for failure or blockage</li> </ul> </li> <li>4. Return air duct has substantial leakage</li> </ol>

*Flash Code number corresponds to a number of LED flashes, followed by a pause and then repeated. TRIP and ALERT LEDs flashing at same time means control circuit voltage is too low for operation.*

## LED Troubleshooting Information Continued

Status LED	Status LED Description	Status LED Troubleshooting Information
<b>Yellow "ALERT" Flash Code 3</b>	<b>Short Cycling</b> Compressor is running only briefly	<ol style="list-style-type: none"> <li>1. Thermostat demand signal is intermittent</li> <li>2. Time delay relay or control board defective</li> <li>3. If high pressure switch present go to Flash Code 2 information</li> </ol>
<b>Yellow "ALERT" Flash Code 4</b>	<b>Locked Rotor</b>	<ol style="list-style-type: none"> <li>1. Run capacitor has failed</li> <li>2. Low line voltage (contact utility if voltage at disconnect is low) <ul style="list-style-type: none"> <li>• Check wiring connections</li> </ul> </li> <li>3. Excessive liquid refrigerant in compressor</li> <li>4. Compressor bearings are seized <ul style="list-style-type: none"> <li>• Measure compressor oil level</li> </ul> </li> </ol>
<b>Yellow "ALERT" Flash Code 5</b>	<b>Open Circuit</b>	<ol style="list-style-type: none"> <li>1. Outdoor unit power disconnect is open</li> <li>2. Compressor circuit breaker or fuse(s) is open</li> <li>3. Compressor contactor has failed open <ul style="list-style-type: none"> <li>• Check compressor contactor wiring and connectors</li> <li>• Check for compressor contactor failure (burned, pitted or open)</li> <li>• Check wiring and connectors between supply and compressor</li> <li>• Check for low pilot voltage at compressor contactor coil</li> </ul> </li> <li>4. High pressure switch is open and requires manual reset</li> <li>5. Open circuit in compressor supply wiring or connections</li> <li>6. Unusually long compressor protector reset time due to extreme ambient temperature</li> <li>7. Compressor windings are damaged <ul style="list-style-type: none"> <li>• Check compressor motor winding resistance</li> </ul> </li> </ol>
<b>Yellow "ALERT" Flash Code 6</b>	<b>Open Start Circuit</b> Current only in run circuit	<ol style="list-style-type: none"> <li>1. Run capacitor has failed</li> <li>2. Open circuit in compressor start wiring or connections <ul style="list-style-type: none"> <li>• Check wiring and connectors between supply and the compressor "S" terminal</li> </ul> </li> <li>3. Compressor start winding is damaged <ul style="list-style-type: none"> <li>• Check compressor motor winding resistance</li> </ul> </li> </ol>
<b>Yellow "ALERT" Flash Code 7</b>	<b>Open Run Circuit</b> Current only in start circuit	<ol style="list-style-type: none"> <li>1. Open circuit in compressor run wiring or connections <ul style="list-style-type: none"> <li>• Check wiring and connectors between supply and the compressor "R" terminal</li> </ul> </li> <li>2. Compressor run winding is damaged <ul style="list-style-type: none"> <li>• Check compressor motor winding resistance</li> </ul> </li> </ol>
<b>Yellow "ALERT" Flash Code 8</b>	<b>Welded Contactor</b> Compressor always runs	<ol style="list-style-type: none"> <li>1. Compressor contactor has failed closed</li> <li>2. Thermostat demand signal not connected to module</li> </ol> <p><b>Note: Disabled on 543-0010-01, 943-0010-01</b></p>
<b>Yellow "ALERT" Flash Code 9</b>	<b>Low Voltage</b> Control circuit < 17VAC	<ol style="list-style-type: none"> <li>1. Control circuit transformer is overloaded</li> <li>2. Low line voltage (contact utility if voltage at disconnect is low) <ul style="list-style-type: none"> <li>• Check wiring connections</li> </ul> </li> </ol>

*Flash Code number corresponds to a number of LED flashes, followed by a pause and then repeated. TRIP and ALERT LEDs flashing at same time means control circuit voltage is too low for operation.*

**NOTE: The correct Comfort Alert model must be used for the application (refer to the Application, Benefits and Product Specifications section on page 3). If the wrong model is installed, or Comfort alert is wired incorrectly, the ALERT Flash Codes for system faults may function incorrectly: Comfort Alert may indicate system faults that are not present or fail to indicate system faults that are present.**

**Table 1 describes LED operation when the module is miswired and what troubleshooting action is required to correct the problem.**

**Table 1**

Miswired Module Indication	Recommended Troubleshooting Action
Green LED is not on, module does not power up	Determine if both R and C module terminals are connected. Verify voltage is present at module's R and C terminals. Review 24VAC Power Wiring (page 6-7) for R and C wiring.
Green LED intermittent, module powers up only when compressor runs	Determine if R and Y terminals are wired in reverse. Verify module's R and C terminals have a constant source. Review 24VAC Power Wiring (page 6-7) for R and C wiring.
TRIP LED is on but system and compressor check OK	Verify Y terminal is connected to 24VAC at contactor coil. Verify voltage at contactor coil falls below 0.5VAC when off. Verify 24VAC is present across Y and C when thermostat demand signal is present. If not, R and C are reverse wired.
TRIP LED and ALERT LED flashing together	Verify R and C terminals are supplied with 19-28VAC.
ALERT Flash Code 5 Open Circuit	Verify Y terminal is connected to 24VAC at contactor coil. Verify voltage at contactor coil falls below 0.5VAC when off.
ALERT Flash Code 6 or 7 (Open Start Circuit or Open Run Circuit) displayed incorrectly	Check that compressor run and start wires are through module's current sensing holes.
ALERT Flash Code 8 (Welded Contactor) displayed incorrectly	Determine if module's Y terminal is connected. Verify Y terminal is connected to 24VAC at contactor coil. Verify 24VAC is present across Y and C when thermostat demand signal is present. If not, R and C are reverse wired. Verify voltage at contactor coil falls below 0.5VAC when off. Review Thermostat Demand Wiring (page 6-7) for Y and C wiring.

## Warranty Information

Emerson Climate Technologies, Inc. warrants its enclosed diagnostic module to be free from defects in materials and workmanship under normal use for a period of one year from the date of purchase or twenty months from manufacture whichever comes first. During this period, we will replace any defective diagnostic module without charge.

This warranty is valid for the original purchaser from the date of initial purchase and is not transferable. Keep the original sales receipt. Proof of purchase is required to obtain warranty replacement. Dealers or service centers selling this product do not have the right to alter, modify or in any way change the terms and conditions of this warranty.

This warranty does not cover normal wear of parts or damage resulting from any of the following: negligent use or misuse of the product, use on improper voltage or current, use contrary to the operating instructions, disassembly, repair or alteration by anyone other than Emerson Climate Technologies, Inc. Further, the warranty does not cover acts of God, such as fire, flood, hurricanes and tornadoes.

### **EMERSON CLIMATE TECHNOLOGIES, INC. MAKES NO IMPLIED WARRANTIES OF MERCHANTABILITY OR FITNESS FOR PARTICULAR PURPOSE WITH RESPECT TO THE COMFORT ALERT MODULE.**

Emerson Climate Technologies, Inc. shall not be liable for any incidental or consequential damages caused by the breach of any express or implied warranty. Some states, provinces, or jurisdictions do not allow the exclusion or limitation of incidental or consequential damages or limitations on how long an implied warranty lasts, so the above limitations or exclusions may not apply to you. This warranty gives you specific legal rights, and you may also have other rights that vary from state to state, or province to province.

Units under warranty and in need of repair should be returned to an authorized wholesaler or original equipment manufacturer.