

Water Cooled Scroll Condensing Unit - User Manual



COPELAND™

EMERSON™

Table of Contents

Content	Page
Introduction	3
Safety Information	4
Nomenclature	6
Dimensional Drawings & Data	6
Performance Data (50Hz & 60Hz)	7
Features & Benefits	13
Scope of Supply	14
Electrical Connections	15
Installation & Startup	16
Operational Checklist	20

Introduction

Emerson Water-Cooled Scroll Condensing Units are fitted with high efficient Copeland Scroll Compressors.

This document is designed to help the contractor and customer for the installation, commissioning & operation of Emerson's Water-Cooled Scroll Condensing Unit.

Scope of supply – Check page number 10 of this manual for detailed scope of supply.

Disclaimer

Thank you for purchasing the Emerson™ Water-Cooled Scroll Condensing Unit. We hope that this product meets your intended refrigeration requirement. Please read through this operation manual to familiarize yourself with the installation, commissioning, and operation of this product. Please do read the following information in this page before proceeding with the rest of the manual.

The Emerson™ Water-Cooled Scroll refrigeration condensing units should only be installed by suitably qualified and experienced refrigeration technicians. No responsibility can be accepted for damage caused by inexperienced or inadequately trained site technicians or improper system design. All instructions and procedures described in this manual are based on good refrigeration trade practices as applicable to this particular product. The installation contractor may prefer to use variations to these recommendations. However, the methods described in this manual represent the minimum requirements to avoid any subsequent warranty claims for this equipment and its components. These instructions do not cover the fundamentals of good electrical or refrigeration practice and are therefore intended for use only by qualified and/or experienced personnel or technicians.







For any additional query, please consult your local sales office, quoting unit model and serial number as shown on the nameplate. In case of ambiguity, the wiring diagram supplied with each unit takes precedence over the diagram in this manual.

1. Safety Information

1.1 Installation and commissioning work on CDU shall be carried out only by qualified, refrigeration personnel who have been trained and instructed.

1.2 Water Cooled Scroll Condensing Unit is manufactured according to the latest safety standards. Emphasis has been placed on the user's safety. For relevant standards please refer to the manufacturer's declaration, available on request. You are strongly advised to follow these safety instructions.

1.3 Icon explanation

 WARNING This icon indicates instructions to avoid personal injury and material damage.	 CAUTION This icon indicates instructions to avoid property damage and possible personal injury.
 High voltage This icon indicates operations with a danger of electric shock.	 IMPORTANT This icon indicates instructions to avoid malfunction of the compressor.
 Danger of burning or frostbite This icon indicates operations with a danger of burning or frostbite.	NOTE This word indicates a recommendation for easier operation.
 Explosion hazard This icon indicates operations with a danger of explosion.	

1.4 Safety Statements

- Only qualified and authorized refrigeration personnel are permitted to install, commission and maintain this equipment.
- Electrical connections must be made by qualified electrical personnel.
- All valid standards for connecting electrical and refrigeration equipment must be observed.
- The national legislation and regulations regarding personnel protection must be observed.



Use personal safety equipment. Safety goggles, gloves, protective clothing, safety boots and hard hats should be worn where necessary.

1.5 General Instructions



WARNING

System breakdown! Personal injuries! Never install a system in the field and leave it unattended when it has no charge, a holding charge, or with the service valves closed without electrically locking out the system. System breakdown! Personal injuries! Only approved refrigerants and refrigeration oils must be used.



WARNING

High shell temperature! Burning! Do not touch the compressor until it has cooled down. Ensure that other materials in the area of the compressor do not get in touch with it. Lock and mark accessible sections.



CAUTION

Overheating! Bearing damage! Do not operate compressors without refrigerant charge or without being connected to the system.



CAUTION

Compressors contain oil & refrigerant under pressure. Release pressure from both high & low side of compressor before servicing.



CAUTION

Tube brazing & compressor operation can produce hot surfaces. To avoid burns, allow surfaces to cool.

1.6 Safety Refrigerants/Lubricant

- a. Please use correct refrigerant as designed to work in safe operating envelope.
- b. Compressor is supplied with an initial oil charge. The standard oil charge for use with HFC refrigerant is polyol ester (POE) lubricant Emkarate RL 32 3MAF.

2. Nomenclature

F M C K A - Z S 1 1 - T F 7 - 0

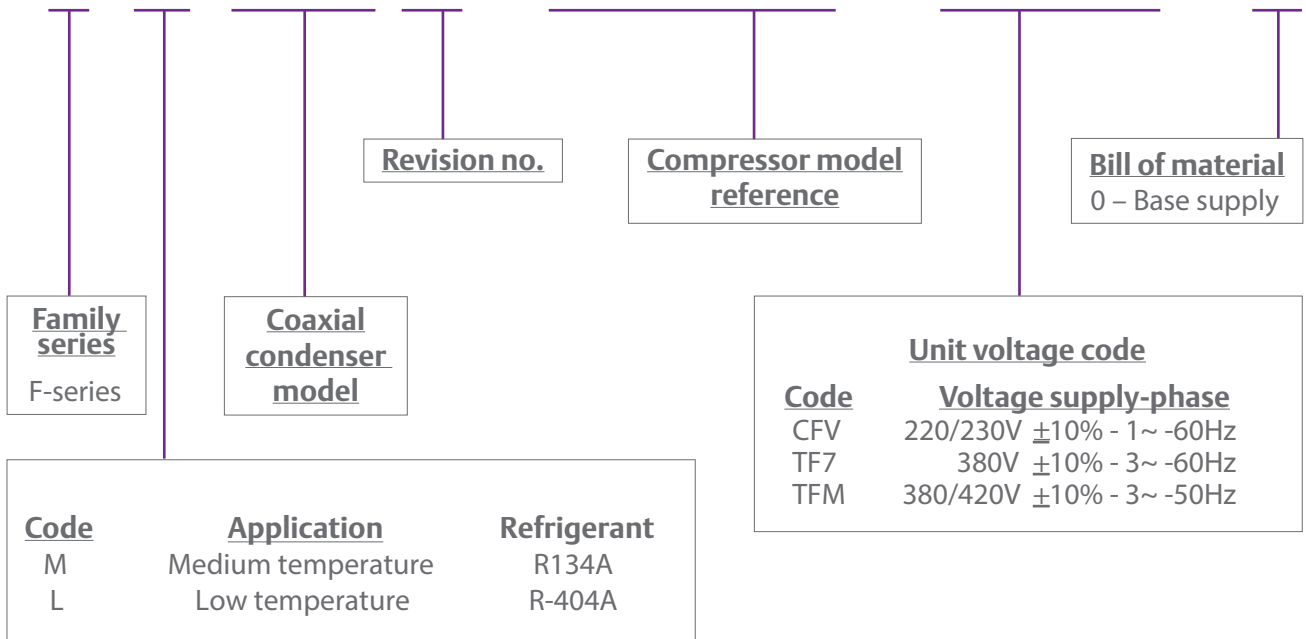

3. Dimensional Drawings & Data

ZB, ZS

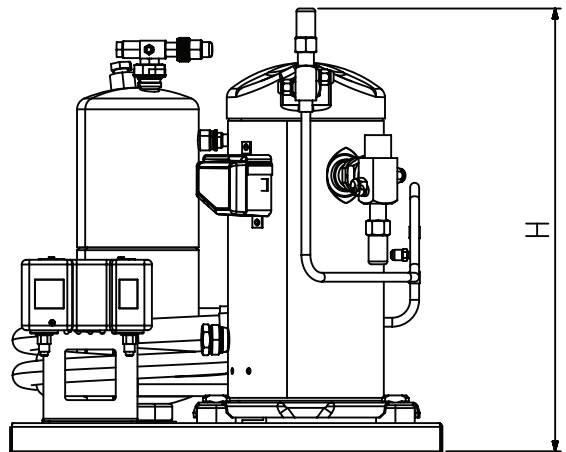
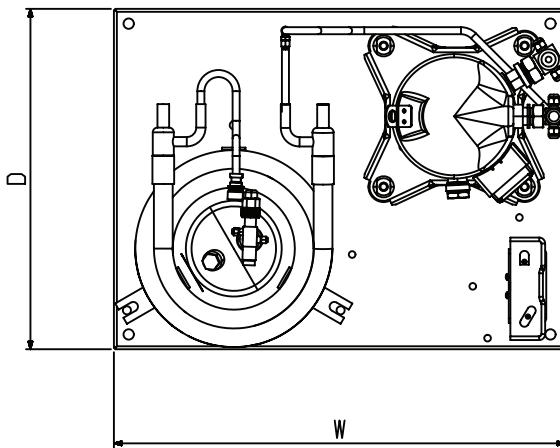

ZF

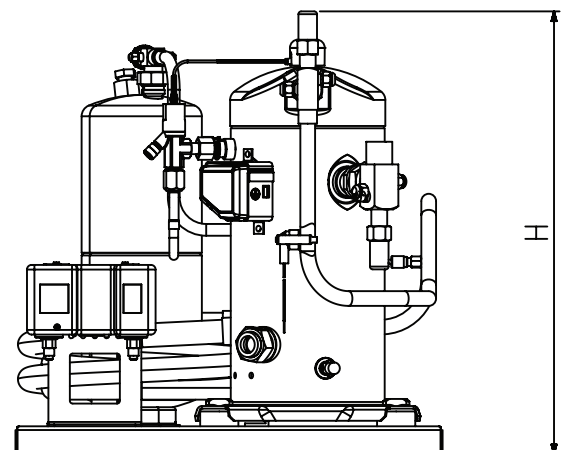
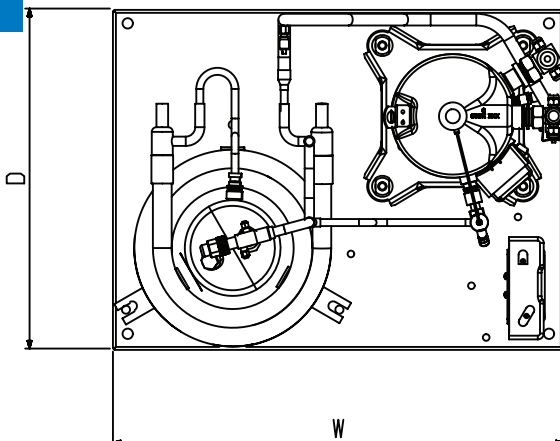

Mechanical Data - 50Hz

Condensing Unit Model	Compressor Model	Receiver Capacity (l)	Depth/Width [D/W] (mm)	Height [H] (mm)	Suction Ø [SL] (")	Liquid Ø [LL] (")	Water Inlet FPT (")	Water Outlet ODF (")	Net Weight (Kg)	Gross Weight (Kg)
FDCKA-ZS09-TFM	ZS09KAE-TFD-600	3.9	460/618	495	5/8	1/2	3/8	5/8	39	49
FDCKA-ZS11-TFM	ZS11KAE-TFD-600	3.9	460/618	495	5/8	1/2	3/8	5/8	39	49
FDCKA-ZS13-TFM	ZS13KAE-TFD-600	3.9	460/618	495	5/8	1/2	3/8	5/8	39	49
FMCKA-ZB15-TFM	ZB15KQE-TFD-559	3.9	460/610	471	3/4	1/2	3/8	5/8	42	52
FMCKA-ZB19-TFM	ZB19KQE-TFD-559	3.9	460/610	471	3/4	1/2	3/8	5/8	44	54
FMCKA-ZB21-TFM	ZB21KQE-TFD-559	3.9	460/610	494	3/4	1/2	3/8	5/8	44	54
FMCNA-ZB26-TFM	ZB26KQE-TFD-559	7.9	570/680	510	7/8	1/2	3/4	7/8	62	77
FMCNA-ZB29-TFM	ZB29KQE-TFD-559	7.9	570/680	527	7/8	1/2	3/4	7/8	66	81
FMCNA-ZB38-TFM	ZB38KQE-TFD-559	7.9	570/680	545	1 1/8	1/2	3/4	7/8	70	85
FMCNA-ZB45-TFM	ZB45KQE-TFD-559	7.9	570/680	545	1 1/8	1/2	3/4	7/8	72	87
FMCPA-ZB48-TFM	ZB48KQE-TFD-559	7.9	610/725	559	1 1/8	1/2	3/4	1 1/8	76	91
FLCKA-ZF06-TFM	ZF06KQE-TFD-551	3.9	460/610	477	3/4	1/2	3/8	5/8	42	52
FLCKA-ZF09-TFM	ZF09KQE-TFD-551	3.9	460/610	499	3/4	1/2	3/8	5/8	44	54
FLCNA-ZF11-TFM	ZF11KQE-TFD-551	7.9	570/680	515	7/8	1/2	3/4	7/8	61	76
FLCNA-ZF13-TFM	ZF13KQE-TFD-551	7.9	570/680	545	7/8	1/2	3/4	7/8	71	86
FLCNA-ZF15-TFM	ZF15KQE-TFD-551	7.9	570/680	545	1 1/8	1/2	3/4	7/8	72	87
FLCNA-ZF18-TFM	ZF18KQE-TFD-551	7.9	570/680	545	1 1/8	1/2	3/4	7/8	74	89

Mechanical Data - 60Hz

Condensing unit model	Compressor model	Receiver capacity (l)	Depth/ width [D/W] (mm)	Height [H] (mm)	Suction Ø [SL] (")	Liquid Ø [LL] (")	Water inlet FPT (")	Water outlet ODF (")	Net weight (kg)	Gross weight (kg)
FMCKA-ZS 11-TF7	ZS11KAE-TF7-600	3.9	460/610	495	5/8	1/2	3/8	5/8	39	49
FMCKA-ZB 15-TF7	ZB15KQE-TF7-559	3.9	460/610	471	3/4	1/2	3/8	5/8	42	52
FMCKA-ZB 19-TF7	ZB19KQE-TF7-559	3.9	460/610	471	7/8	1/2	3/8	5/8	44	54
FMCNA-ZB 21-TF7	ZB21KQE-TF7-559	7.9	570/680	496	7/8	1/2	3/4	7/8	60	75
FMCNA-ZB 26-TF7	ZB26KQE-TF7-559	7.9	570/680	510	7/8	1/2	3/4	7/8	62	77
FMCNA-ZB 29-TF7	ZB29KQE-TF7-559	7.9	570/680	527	1 1/8	1/2	3/4	7/8	66	81
FMCNA-ZB 38-TF7	ZB38KQE-TF7-559	7.9	570/680	545	1 1/8	1/2	3/4	7/8	71	86
FMCPA-ZB 45-TF7	ZB45KQE-TF7-559	7.9	610/725	555	1 1/8	1/2	3/4	1-1/8	76	91
FLCKA-ZF 06-CFV	ZF06KQE-PFV-551	3.9	460/610	477	3/4	1/2	3/8	5/8	45	55
FLCNA-ZF 09-CFV	ZF09KQE-PFV-551	7.9	570/680	501	3/4	1/2	3/4	7/8	62	77
FLCNA-ZF 11-CFV	ZF11KQE-PFV-551	7.9	570/680	515	7/8	1/2	3/4	7/8	62	77
FLCNA-ZF 13-TF7	ZF13KQE-TF7-551	7.9	570/680	546	7/8	1/2	3/4	7/8	73	88
FLCNA-ZF 15-TF7	ZF15KQE-TF7-551	7.9	570/680	546	1 1/8	1/2	3/4	7/8	73	88
FLCPA-ZF 18-TF7	ZF18KQE-TF7-551	7.9	610/725	546	1 1/8	1/2	3/4	1-1/8	76	91

Envelopes

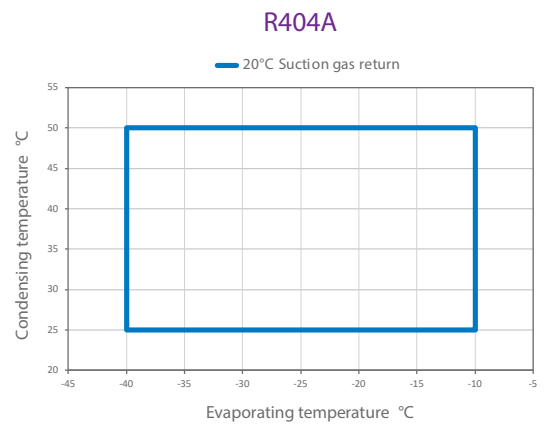
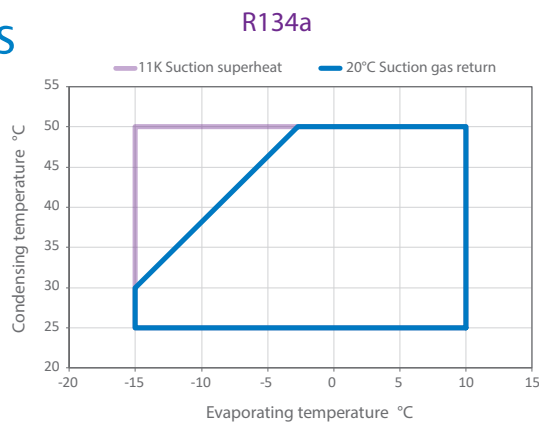

Electrical Data - 50Hz

Condensing Unit Model	Compressor Model	Compressor Maximum Operating Current (A)	Compressor Locked Rotor Current (A)
FDCKA-ZS09-TFM	ZS09KAE-TFD-600	3.0	27.0
FDCKA-ZS11-TFM	ZS11KAE-TFD-600	3.3	27.0
FDCKA-ZS13-TFM	ZS13KAE-TFD-600	4.0	29.0
FMCKA-ZB15-TFM	ZB15KQE-TFD-559	4.9	26.0
FMCKA-ZB19-TFM	ZB19KQE-TFD-559	6.5	32.0
FMCKA-ZB21-TFM	ZB21KQE-TFD-559	7.2	40.0
FMCNA-ZB26-TFM	ZB26KQE-TFD-559	8.9	46.0
FMCNA-ZB29-TFM	ZB29KQE-TFD-559	10.0	50.0
FMCNA-ZB38-TFM	ZB38KQE-TFD-559	12.8	65.5
FMCNA-ZB45-TFM	ZB45KQE-TFD-559	13.1	74.0
FMCPA-ZB48-TFM	ZB48KQE-TFD-559	14.0	101.0
FLCKA-ZF06-TFM	ZF06KQE-TFD-551	5.0	26.0
FLCKA-ZF09-TFM	ZF09KQE-TFD-551	6.0	40.0
FLCNA-ZF11-TFM	ZF11KQE-TFD-551	7.1	46.0
FLCNA-ZF13-TFM	ZF13KQE-TFD-551	8.0	51.5
FLCNA-ZF15-TFM	ZF15KQE-TFD-551	10.0	64.0
FLCNA-ZF18-TFM	ZF18KQE-TFD-551	12.5	74.0

Electrical Data - 60Hz

Condensing unit model	Compressor model	Compressor maximum operating current (A)	Compressor locked rotor current (A)
FMCKA-ZS 11-TF7	ZS11KAE-TF7-600	3.9	29
FMCKA-ZB 15-TF7	ZB15KQE-TF7-559	5.1	27
FMCKA-ZB 19-TF7	ZB19KQE-TF7-559	6.0	30
FMCNA-ZB 21-TF7	ZB21KQE-TF7-559	7.2	39
FMCNA-ZB 26-TF7	ZB26KQE-TF7-559	8.8	41
FMCNA-ZB 29-TF7	ZB29KQE-TF7-559	10.0	54
FMCNA-ZB 38-TF7	ZB38KQE-TF7-559	13.0	64
FMCPA-ZB 45-TF7	ZB45KQE-TF7-559	13.1	70
FLCKA-ZF 06-CFV	ZF06KQE-PFV-551	17.1	61
FLCNA-ZF 09-CFV	ZF09KQE-PFV-551	20.2	88
FLCNA-ZF 11-CFV	ZF11KQE-PFV-551	24.7	109
FLCNA-ZF 13-TF7	ZF13KQE-TF7-551	10.0	57
FLCNA-ZF 15-TF7	ZF15KQE-TF7-551	12.0	64
FLCPA-ZF 18-TF7	ZF18KQE-TF7-551	14.0	70

Fluid data - 50Hz

Medium temperature

R134a

Condensing Unit Model	Condensing Temperature (°C)	Water Flow Rate (l/s)					Pressure Drop (kPa)				
		Evaporating Temperature (°C)									
		-15	-10	-5	0	5	-15	-10	-5	0	5
FDCKA-ZS09-TFM	30	0.07	0.08	0.10	0.12	0.14	2.76	4.00	4.55	6.48	7.86
	35	0.07	0.08	0.10	0.12	0.14	2.76	3.45	4.55	6.07	7.86
	40	0.07	0.08	0.10	0.11	0.14	2.76	3.45	4.55	5.79	7.72
	45	0.06	0.08	0.09	0.11	0.13	2.76	3.45	4.55	5.79	7.17
FDCKA-ZS11-TFM	30	0.08	0.10	0.12	0.14	0.17	3.45	4.69	6.34	8.14	10.62
	35	0.08	0.10	0.11	0.14	0.16	3.45	4.69	5.93	8.14	10.07
	40	0.08	0.09	0.11	0.14	0.16	3.45	4.69	5.93	7.86	9.93
	45	0.08	0.09	0.11	0.13	0.15	3.45	4.69	5.93	7.45	9.93
FDCKA-ZS13-TFM	30	0.09	0.11	0.13	0.16	0.19	4.14	5.93	7.72	10.20	12.82
	35	0.09	0.11	0.13	0.16	0.19	4.14	5.38	7.31	9.51	12.69
	40	0.09	0.11	0.13	0.15	0.18	4.14	5.38	7.31	9.51	12.13
	45	0.09	0.11	0.13	0.15	0.18	4.14	5.38	7.03	8.83	12.00
FMCKA-ZB15-TFM	30	0.11	0.13	0.16	0.19	0.22	5.52	7.31	9.79	12.55	17.10
	35	0.10	0.12	0.15	0.18	0.22	4.83	6.76	9.10	12.55	16.41
	40	0.10	0.12	0.15	0.18	0.21	4.83	6.76	9.10	11.86	15.72
	45	0.10	0.12	0.15	0.18	0.21	4.83	6.62	8.41	11.58	15.03
FMCKA-ZB19-TFM	30	0.12	0.15	0.18	0.22	0.26	6.21	8.69	11.86	16.27	21.37
	35	0.12	0.14	0.18	0.21	0.25	6.21	8.69	11.58	15.58	20.68
	40	0.12	0.14	0.17	0.21	0.24	6.21	8.14	11.17	14.89	19.86
	45	0.11	0.14	0.17	0.20	0.24	6.21	8.00	10.89	14.20	19.17
FMCKA-ZB21-TFM	30	0.15	0.19	0.22	0.27	0.32	8.96	12.69	16.82	23.03	30.75
	35	0.15	0.18	0.22	0.26	0.32	8.96	12.00	16.82	22.34	29.92
	40	0.15	0.18	0.21	0.26	0.31	8.96	12.00	16.13	21.37	28.54
	45	0.15	0.17	0.21	0.25	0.30	8.27	11.45	15.44	20.68	27.17
FMCNA-ZB26-TFM	30	0.18	0.21	0.26	0.31	0.37	11.72	12.27	12.82	14.07	16.13
	35	0.17	0.21	0.25	0.30	0.37	11.72	11.72	12.82	14.07	16.13
	40	0.17	0.20	0.25	0.30	0.35	11.72	11.72	12.82	14.07	15.44
	45	0.16	0.20	0.24	0.29	0.35	11.72	11.72	12.41	13.38	15.44
FMCNA-ZB29-TFM	30	0.19	0.23	0.28	0.34	0.41	11.72	12.27	13.51	15.03	17.65
	35	0.19	0.23	0.28	0.33	0.40	11.72	12.27	13.51	15.03	17.51
	40	0.19	0.23	0.27	0.33	0.39	11.72	12.27	13.51	14.75	16.96
	45	0.18	0.22	0.27	0.32	0.38	11.72	12.27	12.82	14.34	16.82
FMCNA-ZB38-TFM	30	0.25	0.31	0.38	0.45	0.54	13.10	14.20	16.41	19.72	25.65
	35	0.25	0.30	0.37	0.44	0.53	12.41	14.20	16.00	19.44	24.27
	40	0.25	0.30	0.36	0.43	0.51	12.41	13.65	16.00	18.75	23.44
	45	0.24	0.29	0.35	0.42	0.50	12.41	13.65	15.31	18.48	22.75
FMCNA-ZB45-TFM	30	0.30	0.37	0.45	0.54	0.65	13.79	16.27	19.86	25.51	34.34
	35	0.30	0.36	0.44	0.53	0.63	13.79	15.58	19.17	24.41	32.82
	40	0.29	0.35	0.43	0.51	0.62	13.79	15.58	18.48	23.44	31.44
	45	0.28	0.35	0.42	0.50	0.60	13.79	15.03	18.48	22.75	29.92
FMCPA-ZB48-TFM	30	0.35	0.42	0.51	0.61	0.72	7.58	10.62	14.34	19.31	25.65
	35	0.35	0.42	0.50	0.59	0.71	7.58	10.62	14.07	18.62	24.82
	40	0.34	0.41	0.49	0.58	0.69	7.58	10.07	13.65	18.34	23.58
	45	0.33	0.40	0.48	0.57	0.67	6.89	9.93	12.96	17.65	22.75

Fluid data - 50Hz

Low temperature

R404a

Condensing Unit Model	Condensing Temperature (°C)	Capacity (kW)						Power Input (kW)					
		Evaporating Temperature (°C)											
		-40	-35	-30	-25	-20	-15	-40	-35	-30	-25	-20	-15
FDCKA-ZS09-TFM	30			1.13	1.41	1.83	2.25			0.68	0.71	0.80	0.81
	35			1.07	1.33	1.70	2.10			0.74	0.78	0.87	0.89
	40			1.00	1.24	1.57	1.95			0.81	0.86	0.95	0.98
	45			0.93	1.16	1.45	1.80			0.90	0.96	1.04	1.08
FDCKA-ZS11-TFM	30			1.37	1.71	2.19	2.70			0.81	0.85	0.91	0.94
	35			1.29	1.61	2.04	2.52			0.88	0.93	0.99	1.03
	40			1.21	1.51	1.88	2.34			0.97	1.03	1.08	1.12
	45			1.13	1.40	1.74	2.16			1.08	1.14	1.19	1.23
FDCKA-ZS13-TFM	30			1.54	1.93	2.50	3.08			0.93	0.98	1.07	1.10
	35			1.45	1.81	2.32	2.88			1.01	1.07	1.17	1.20
	40			1.37	1.69	2.14	2.67			1.11	1.18	1.27	1.32
	45			1.28	1.57	1.98	2.46			1.23	1.31	1.39	1.44
FLCKA-ZF06-TFM	30	1.32	1.66	2.07	2.54	3.10	3.76	1.17	1.23	1.30	1.37	1.45	1.54
	35	1.25	1.57	1.95	2.41	2.93	3.55	1.28	1.33	1.40	1.47	1.55	1.64
	40	1.17	1.48	1.84	2.26	2.75	3.33	1.40	1.46	1.52	1.59	1.67	1.75
	45	1.09	1.38	1.71	2.11	2.56	3.09	1.55	1.60	1.66	1.73	1.80	1.89
FLCKA-ZF09-TFM	30	1.76	2.24	2.80	3.46	4.23	5.12	1.45	1.47	1.51	1.57	1.64	1.73
	35	1.67	2.13	2.65	3.27	3.99	4.83	1.60	1.62	1.65	1.70	1.77	1.86
	40	1.58	2.01	2.50	3.07	3.74	4.52	1.77	1.78	1.81	1.85	1.92	2.00
	45	1.48	1.88	2.34	2.86	3.48	4.20	1.95	1.96	1.98	2.03	2.09	2.16
FLCNA-ZF11-TFM	30	2.24	2.83	3.51	4.32	5.26	6.36	1.79	1.82	1.86	1.93	2.03	2.14
	35	2.13	2.69	3.34	4.09	4.97	6.00	1.95	1.97	2.02	2.09	2.17	2.28
	40	2.01	2.54	3.14	3.84	4.66	5.62	2.13	2.15	2.20	2.26	2.34	2.45
	45	1.88	2.37	2.93	3.58	4.33	5.22	2.32	2.35	2.39	2.45	2.54	2.64
FLCNA-ZF13-TFM	30	2.53	3.25	4.10	5.09	6.23	7.53	1.87	1.93	2.00	2.08	2.19	2.30
	35	2.40	3.07	3.86	4.78	5.86	7.09	2.06	2.12	2.19	2.28	2.37	2.49
	40	2.27	2.88	3.61	4.47	5.47	6.62	2.27	2.33	2.41	2.49	2.59	2.70
	45	2.15	2.70	3.36	4.14	5.06	6.13	2.51	2.58	2.65	2.74	2.84	2.95
FLCNA-ZF15-TFM	30	3.11	4.01	5.06	6.27	7.67	9.30	2.21	2.33	2.45	2.58	2.73	2.90
	35	2.93	3.78	4.76	5.89	7.21	8.74	2.44	2.56	2.68	2.82	2.97	3.14
	40	2.76	3.54	4.45	5.49	6.72	8.14	2.68	2.82	2.95	3.09	3.24	3.41
	45	2.61	3.31	4.13	5.08	6.20	7.50	2.96	3.10	3.25	3.40	3.55	3.72
FLCNA-ZF18-TFM	30	3.82	4.84	6.03	7.42	9.06	11.00	2.79	2.89	3.01	3.14	3.29	3.46
	35	3.62	4.59	5.71	7.01	8.54	10.35	3.03	3.13	3.25	3.39	3.55	3.71
	40	3.42	4.33	5.37	6.57	7.99	9.65	3.29	3.40	3.53	3.67	3.83	4.00
	45	3.19	4.04	5.00	6.11	7.41	8.94	3.59	3.71	3.84	3.98	4.14	4.31

Operating Conditions: 20 °C Suction Gas Return Temperature and 3K Sub Cooling

 4.4 °C Suction Gas Return Temperature

Fluid data - 60Hz

Medium temperature

R134a

Condensing unit model	Condensing temperature (°C)	Water flow rate (l/s)					Pressure drop (kPa)				
		Evaporating temperature (°C)									
		-15	-10	-5	0	5	-15	-10	-5	0	5
FMCKA-ZS 11-TF7	30	0.10	0.12	0.14	0.17	0.21	4.8	6.6	8.4	11.2	14.4
	35	0.09	0.12	0.14	0.17	0.20	4.8	6.1	8.4	10.9	14.2
	40	0.09	0.12	0.14	0.16	0.19	4.8	6.1	8.0	10.2	13.5
	45	0.09	0.11	0.13	0.16	0.19	4.8	6.1	7.7	10.2	12.8
FMCKA-ZB 15-TF7	30	0.13	0.16	0.19	0.23	0.28	6.9	9.9	13.4	17.9	24.2
	35	0.13	0.15	0.19	0.22	0.27	6.9	9.4	13.0	17.3	22.9
	40	0.13	0.15	0.18	0.22	0.26	6.9	9.2	12.3	17.0	22.1
	45	0.12	0.15	0.18	0.22	0.26	6.2	8.7	12.3	16.3	21.4
FMCKA-ZB 19-TF7	30	0.15	0.18	0.22	0.27	0.32	9.0	12.0	16.8	22.8	30.1
	35	0.15	0.18	0.22	0.26	0.31	8.3	12.0	16.1	22.1	29.3
	40	0.15	0.17	0.21	0.26	0.30	8.3	11.3	15.5	21.4	27.9
	45	0.14	0.17	0.21	0.25	0.30	8.3	11.3	15.0	20.4	27.0
FMCNA-ZB 21-TF7	30	0.18	0.23	0.28	0.33	0.40	11.7	12.3	13.5	15.0	17.5
	35	0.18	0.22	0.27	0.33	0.39	11.7	12.3	13.1	14.8	17.0
	40	0.18	0.22	0.26	0.32	0.38	11.7	12.3	12.8	14.4	16.8
	45	0.18	0.22	0.26	0.32	0.37	11.7	12.3	12.8	14.4	16.1
FMCNA-ZB 26-TF7	30	0.21	0.26	0.32	0.39	0.46	11.7	13.0	14.6	16.7	20.6
	35	0.21	0.25	0.31	0.38	0.45	11.7	13.0	14.2	16.4	19.9
	40	0.20	0.25	0.30	0.37	0.44	11.7	13.0	14.2	16.4	19.2
	45	0.20	0.25	0.30	0.36	0.43	11.7	12.4	13.9	15.7	19.0
FMCNA-ZB 29-TF7	30	0.23	0.28	0.34	0.42	0.50	12.4	13.7	15.3	18.1	22.6
	35	0.23	0.28	0.34	0.41	0.49	12.4	13.7	15.3	17.8	21.9
	40	0.22	0.27	0.33	0.40	0.48	12.4	13.0	14.9	17.4	21.3
	45	0.22	0.27	0.33	0.39	0.46	12.4	13.0	14.6	17.1	20.6
FMCNA-ZB 38-TF7	30	0.31	0.38	0.46	0.56	0.67	13.8	16.3	20.3	26.8	36.6
	35	0.30	0.37	0.45	0.55	0.66	13.8	16.3	19.9	25.8	35.1
	40	0.30	0.36	0.44	0.53	0.64	13.8	16.3	19.6	25.1	33.5
	45	0.29	0.36	0.43	0.52	0.62	13.8	15.6	19.2	24.2	32.2
FMCPA-ZB 45-TF7	30	0.37	0.45	0.55	0.66	0.80	8.3	12.0	16.8	22.8	29.9
	35	0.36	0.44	0.54	0.65	0.78	8.3	11.3	16.1	21.7	29.1
	40	0.35	0.43	0.53	0.63	0.75	7.6	11.3	15.5	20.7	27.7
	45	0.35	0.42	0.51	0.61	0.73	7.6	10.6	14.8	20.0	26.4

Note: Operating conditions : 20°C suction gas return temperature and 3K subcooling

Fluid data - 60Hz

Low temperature

R404a

Condensing unit model	Condensing temperature (°C)	Capacity (kW)						Power Input (kW)					
		Evaporating temperature (°C)											
		-40	-35	-30	-25	-20	-15	-40	-35	-30	-25	-20	-15
FLCKA-ZF 06-CFV	30	1.58	2.00	2.49	3.08	3.72	4.51	1.37	1.39	1.45	1.54	1.65	1.77
	35	1.48	1.89	2.36	2.90	3.52	4.25	1.52	1.53	1.58	1.66	1.77	1.89
	40	1.38	1.77	2.21	2.71	3.28	3.96	1.70	1.69	1.73	1.81	1.91	2.03
	45	1.28	1.66	2.07	2.53	3.05	3.69	1.89	1.87	1.90	1.97	2.07	2.19
FLCNA-ZF 09-CFV	30	2.23	2.82	3.52	4.31	5.25	6.36	1.71	1.76	1.83	1.93	2.04	2.17
	35	2.11	2.67	3.31	4.07	4.95	5.98	1.88	1.93	1.99	2.08	2.19	2.32
	40	1.98	2.51	3.11	3.81	4.63	5.60	2.08	2.11	2.17	2.26	2.36	2.49
	45	1.85	2.34	2.91	3.55	4.31	5.19	2.29	2.32	2.38	2.45	2.55	2.68
FLCNA-ZF 11-CFV	30	2.75	3.49	4.34	5.36	6.54	7.91	2.05	2.13	2.23	2.36	2.52	2.71
	35	2.62	3.31	4.13	5.07	6.18	7.47	2.26	2.33	2.43	2.56	2.71	2.89
	40	2.47	3.11	3.87	4.75	5.80	7.01	2.49	2.56	2.66	2.78	2.93	3.10
	45	2.31	2.91	3.60	4.43	5.39	6.48	2.74	2.81	2.91	3.03	3.17	3.34
FLCNA-ZF 13-TF7	30	3.04	3.92	4.94	6.12	7.47	9.00	2.24	2.30	2.39	2.50	2.65	2.82
	35	2.86	3.68	4.63	5.74	7.02	8.48	2.46	2.52	2.60	2.71	2.85	3.02
	40	2.69	3.44	4.32	5.35	6.54	7.92	2.70	2.76	2.85	2.95	3.09	3.25
	45	2.53	3.20	3.99	4.93	6.04	7.32	2.98	3.05	3.13	3.23	3.36	3.52
FLCNA-ZF 15-TF7	30	3.86	4.87	6.07	7.48	9.14	11.07	2.70	2.79	2.92	3.07	3.26	3.49
	35	3.65	4.60	5.72	7.05	8.60	10.41	2.94	3.06	3.19	3.35	3.53	3.76
	40	3.42	4.32	5.36	6.59	8.03	9.71	3.19	3.34	3.49	3.66	3.85	4.07
	45	3.19	4.02	4.98	6.11	7.44	8.99	3.47	3.65	3.83	4.01	4.21	4.43
FLCPA-ZF 18-TF7	30	4.60	5.85	7.29	8.97	10.94	13.25	3.27	3.37	3.52	3.72	3.96	4.24
	35	4.37	5.54	6.90	8.47	10.30	12.45	3.57	3.66	3.81	4.02	4.26	4.54
	40	4.13	5.23	6.49	7.94	9.64	11.63	3.88	3.98	4.13	4.34	4.59	4.87
	45	3.89	4.91	6.07	7.40	8.96	10.78	4.21	4.32	4.48	4.69	4.95	5.24

Note: Operating conditions : 20°C suction gas return temperature and 3K subcooling

4. Features & Benefits

Efficiency

- High efficiency Copeland™ ZB/ZF/ZS compressors for multiple application.

Reliability

- Compressors are supplied with internal thermal protectors that safeguards against motor overheating and high current.
- Dual compliance for better reliability.

Smooth Operation

- Scroll compressor has an inbuilt check valve that isolates high pressure gas, allowing the compressor to start unloaded with low inrush currents.
- Less vibration.

Maintenance

- Optimal layout of components for easy serviceability.

5. Physical Layout of Condensing Unit

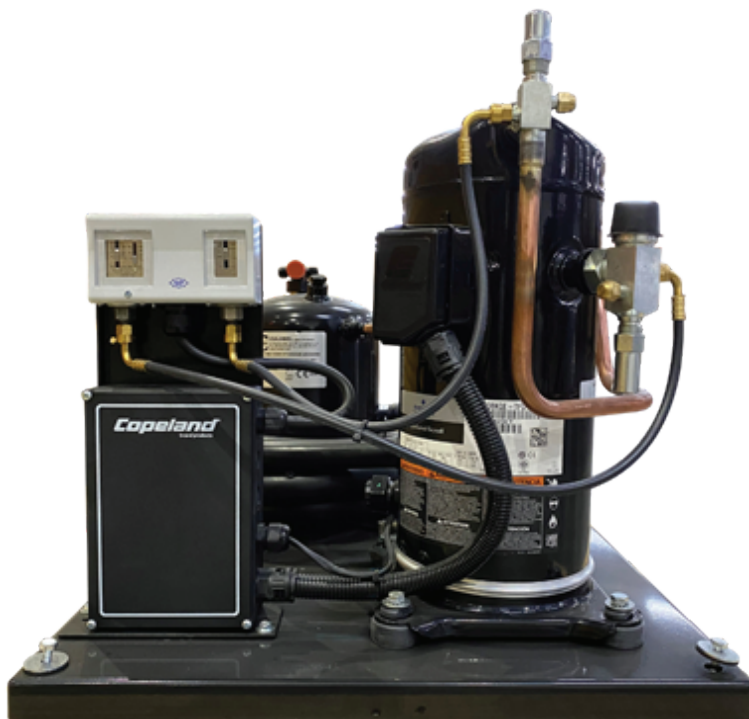

6. Scope of Supply

- High efficiency scroll compressor
- Co-axial condenser
- Compressor with Oil Sight Glass and Crank Case Heater
- HP/LP switch
- Condenser pressure regulator to be provided by the customer as required.

The Condenser Pressure Regulator could be selected from below table. This could be provided as additional accessory.

New Models	Condenser Pressure Regulator PCN
FDCKA-ZS09-TFM-0	510-0049-00
FDCKA-ZS11-TFM-0	510-0049-00
FDCKA-ZS13-TFM-0	510-0049-00
FMCKA-ZB15-TFM-0	510-0049-00
FMCKA-ZB19-TFM-0	510-0049-00
FMCKA-ZB21-TFM-0	510-0049-00
FMCNA-ZB26-TFM-0	510-0049-02
FMCNA-ZB29-TFM-0	510-0049-02
FMCNA-ZB38-TFM-0	510-0049-02
FMCNA-ZB45-TFM-0	510-0049-02
FMCPA-ZB48-TFM-0	510-0049-02
FLCKA-ZF06-TFM-0	510-0049-00
FLCKA-ZF09-TFM-0	510-0049-00
FLCNA-ZF11-TFM-0	510-0049-02
FLCNA-ZF13-TFM-0	510-0049-02
FLCNA-ZF15-TFM-0	510-0049-02
FLCNA-ZF18-TFM-0	510-0049-02

The maximum operating pressure limit on the water side of the Co-axial condenser is 500 psig. However, for the given requirement, please ensure that the water side pressure is within the maximum limit of water pressure regulator.

7. Electrical Connections

F Series Condensing Unit	TFM	TF7	052-2988-00												
Compressor	ZB,ZS,ZF-TFD	ZB,ZS,ZF-TF7													
X1 (L-N)	230 ± 10% V/1/50Hz	230 ± 10% V/1/60Hz													
X2 (L1-L2-L3)	400 ± 10% V/3/50Hz	380 ± 10% V/3/60Hz													
			Rev 01												
		<p>Remarks:</p> <ul style="list-style-type: none"> A5 = Terminal Box Compressor A7 = Terminal Box Condensing Unit B1 = Room Thermostat F3 = Pressure Control Switch F11 = Internal Over-Current Thermal Protector F13 = Discharge Gas Thermostat (If Fitted) H4 = Signal Lamp F3 High Discharge Pressure (If Fitted) K1 = Contactor M1 K6 = Relay Unit Alarm (If Fitted) M1 = Compressor Motor R2 = Crankcase Heater X1 = Terminal Block X2 = Terminal Block 													
<p>Typical Control Circuit</p>		<p>Cable Colours:</p> <table border="0"> <tr> <td>WH = White</td> <td>BU = Blue</td> <td>LGY = Light Grey</td> </tr> <tr> <td>GY = Grey</td> <td>RD = Red</td> <td>CGY = Charcoal Grey</td> </tr> <tr> <td>BK = Black</td> <td>YE = Yellow</td> <td></td> </tr> <tr> <td>BN = Brown</td> <td>G/Y = Green/Yellow</td> <td></td> </tr> </table>		WH = White	BU = Blue	LGY = Light Grey	GY = Grey	RD = Red	CGY = Charcoal Grey	BK = Black	YE = Yellow		BN = Brown	G/Y = Green/Yellow	
WH = White	BU = Blue	LGY = Light Grey													
GY = Grey	RD = Red	CGY = Charcoal Grey													
BK = Black	YE = Yellow														
BN = Brown	G/Y = Green/Yellow														

F Series Condensing Unit	CFZ	CFV	052-3145-00												
Compressor	ZB,ZS,ZF-PFJ	ZB,ZS,ZF-PFV													
X1/X2 (L-N)	230 ± 10% V/1/50Hz	230 ± 10% V/1/60Hz													
				Rev 00											
		<p>Remarks:</p> <ul style="list-style-type: none"> A3 = Capacitor/ Relay Assembly A5 = Terminal Box Compressor A7 = Terminal Box Condensing Unit B1 = Room Thermostat C2 = Run Capacitor M1 C3 = Start Capacitor M1 F3 = Pressure Control Switch F11 = Internal Over-Current Thermal Protector F13 = Discharge Gas Thermostat (If Fitted) H4 = Signal Lamp F3 High Discharge Pressure (If Fitted) K1 = Contactor M1 K6 = Relay Unit Alarm (If Fitted) M1 = Compressor Motor R2 = Crankcase Heater X1 = Terminal Block X2 = Terminal Block 													
<p>Typical Control Circuit</p>		<p>Cable Colours:</p> <table border="0"> <tr> <td>WH = White</td> <td>BU = Blue</td> <td>LGY = Light Grey</td> </tr> <tr> <td>GY = Grey</td> <td>RD = Red</td> <td>CGY = Charcoal Grey</td> </tr> <tr> <td>BK = Black</td> <td>YE = Yellow</td> <td></td> </tr> <tr> <td>BN = Brown</td> <td>G/Y = Green/Yellow</td> <td></td> </tr> </table>		WH = White	BU = Blue	LGY = Light Grey	GY = Grey	RD = Red	CGY = Charcoal Grey	BK = Black	YE = Yellow		BN = Brown	G/Y = Green/Yellow	
WH = White	BU = Blue	LGY = Light Grey													
GY = Grey	RD = Red	CGY = Charcoal Grey													
BK = Black	YE = Yellow														
BN = Brown	G/Y = Green/Yellow														

8. Installation, System Processing and Commissioning

Utmost care must be taken while handling the Water-Cooled Scroll condensing unit. Please go through the contents below to ensure proper handling.

a. Inspection

Inspect the condensing unit and any accessories shipped with them for damages or shortages before and during unloading. All items on bill of lading should be accounted for prior to signing the shipping receipt. Note any shortages or damage on delivery receipt (specify the extent and type of damage found). Unit should be inspected carefully for concealed damage. Notify Emerson sales/application personnel of the damage immediately. Do not repair the unit until instructed by Emerson's representative.

The system is shipped with a holding charge of dry nitrogen. Check to see that pressure is still in the unit upon receipt. Report lack of pressure immediately to the Emerson's application/sales representative.

b. Location and Fixing

Generally installed on the top of the cold room to reduce the connection length between the condensing unit and the evaporator. Enough space to be provided around the unit for easy service. Also ensure easy access to the unit.

c. Refrigeration Piping Installation

All interconnecting pipes should be of refrigeration grade, clean, dehydrated and must remain capped at both ends until installation. Even during installation, if the system is left for any reasonable period (say two hours), pipes should be re-capped to prevent moisture and contaminants from entering the system.

Do not assume that the service connection sizes on the unit (at the service valves) are the correct size to run your interconnecting refrigeration pipes. The service valve sizes have been selected for convenience of installation and in some cases (larger units) these may be considered too small. However, for the very short pipe run within our units, these service connection sizes are adequate.

The pipe should be sized to ensure optimum performance and proper oil return. The sizing must also consider the full capacity range through which this particular unit will need to operate.

Pipe runs should be kept as short as possible, using the minimum number of directional changes. Use large radius bends and avoid trapping of oil and refrigerant. This is particularly important for the suction line. The suction line should ideally slope gently towards the unit. Recommendation slope is 1/200~1/250. P traps, double risers and reduced pipe diameters may be required for suction lines where long vertical risers cannot be avoided. All pipes should be adequately supported to prevent sagging which can create oil traps.

The recommended pipe clamp support distance is shown in the table.

Tube Dia	Max distance between 2 clamp supports
1/2 inch	1.2 M
5/8 inch	1.5 M
7/8 inch	1.8M
1 1/8 inch	2.1M
1 3/8 inch	2.3M

d. Refrigerant line insulation

- Insulate suction lines from the evaporators to the condensing unit with minimum of 1” thickness closed-cell type insulation.
- Long liquid lines run in areas exposed to high temperatures should be fully insulated with minimum 1/2” insulation.
- Suction and liquid lines should never be taped or soldered together.

e. Electrical

- All electrical work must be done in accordance with the National Electrical Code and existing local codes.
- Power supply must be the same as specified on the unit’s name plate.
- Voltage fluctuations in excess of 10 percent must be corrected.
- Before starting the unit, ensure that all protective devices are in place and that all wiring is secure.

f. Brazing Recommendation

Maintain a flow of oxygen-free nitrogen through the system at a very low pressure during brazing. Nitrogen displaces the air and prevents the formation of copper oxides in the system. If copper oxidization is allowed to form, the copper oxide material can later be swept through the system and block screens such as those protecting capillary tubes, thermal expansion valves, and accumulator oil return holes. This minimizes any entry of contaminants and moisture.

- Remove the liquid line connection cap.
- Then remove the suction connection cap.
- Open both valves midway.
- Care should be taken to avoid the holding charge from releasing too quickly.
- Be sure tube fitting inner diameter and tube outer diameter are clean prior to assembly.
- Recommended brazing materials: a copper / phosphorous or copper / phosphorous / silver alloy rod should be used for joining copper to copper whereas to join dissimilar or ferric metals, use a silver alloy rod, either flux coated or with a separate.
- Use a double tip torch.

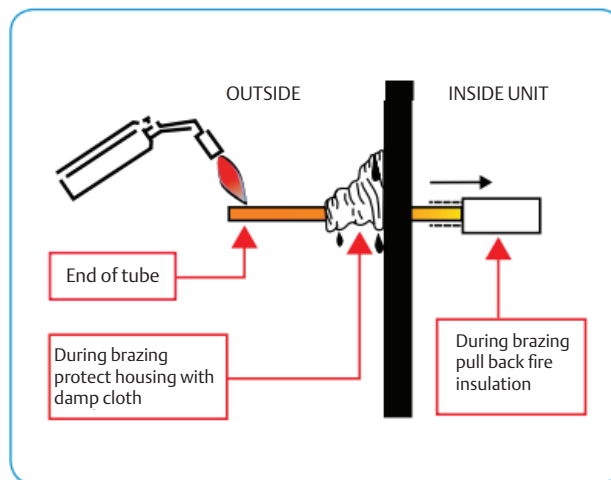

g. Start-up & Operation

Initial pressure test (by vacuum and nitrogen)

Step-by-step

- Use a 4-port gauge manifold with 3/8" hose and connections to the vacuum pump. The vacuum gauge does not have to be connected for this part of the process.
- Connect the gauges to service ports provided on receiver valve and suction tube. In order to remove any non-condensable that may have entered the system during installation, follow these steps:
- Start the vacuum pump. The evaporator fan should be running and the compressor crankcase heater is energized at this point. This will involve powering up the unit so it is important to disconnect the live feed wire to the compressor contactor (so the compressor cannot run and the crank case heater can be energized).
- Open both valves on the manifold and then open the main vacuum valve on the pump. Run the system until the vacuum level of -0.85 bar (as read on manifold gauge) is achieved.
- Shut off the main vacuum pump valve. Check for vacuum rise using the manifold compound gauge. A rise would indicate a large leak.
- If vacuum holds for 10 minutes, break vacuum with Nitrogen. Check the name plate of the unit / compressor for allowable leak test pressure. Ensure that pressure regulators are installed on the Nitrogen cylinders. Check for leaks and repair leakage.

Leak Check

The success of all the subsequent commissioning depends on a leak free system, free of contaminants, free of oxides, free of non-condensables, that has been evacuated to a low vacuum and charged with the prescribed refrigerant.

Leak test is particularly important for field-connected systems. Typically, field systems lose as much as 20%–30% of their refrigeration charge annually. This is not only an unnecessary expense but also damages the environment. Compressor oil can be lost at the same time as refrigerant and eventually lead to compressor failure. (Time spent on leak test will eventually reduce the time spent on the evacuation process).

Ensure that all service valves are open during the leak test process. It is important to recheck all joints within the unit as well as the external joints.

- a. The unit is shipped with a holding charge of dry nitrogen and should be leak free.
- b. Ensure that the test pressure do not exceed the system design pressures.
- c. Do not expose system pressure control LP to test pressures above the design pressure. This can damage the pressure controls.
- d. Using an approved, calibrated electronic gas leak detector, leak test the entire system paying attention to all joints (you might have to charge small quantity of refrigerant before charging the Nitrogen to enable this procedure).
- e. Periodically check functionality of the electronic leak detector during this process.
- f. To further check system integrity, spray a soapy water solution over joints then visually inspect for bubbles.
- g. Leave the system under pressure for a designated period (24 Hours).
- h. Check and record the ambient temperatures and the system pressure with calibrated approved instruments. This process is to be carried out every 8-12 hours during the pressure testing process.
- i. If the test pressures cannot be maintained, repeat the leak testing process employing the isolation of sections of the system to determine the source of leaks. Repair the leak and repeat the leak testing process until system can be signed off as leak free and approved by authorized personnel.
- j. Record findings and confirm pressure testing process completion.

Evacuation

- a. After the system is leak checked, connect approved dual stage vacuum pump sized to application with preferably fresh oil to evacuate the system.
- b. Ensure all inline system shut-off valves and solenoid valves are fully open.
- c. Evacuate the system to 300 microns.
- d. A triple evacuation is recommended in case of using analog gauges as we might not know the exact vacuum level being achieved

Charging and commissioning

Reminder

- The scroll compressor design requires system charging with liquid refrigerant into the liquid line.
- Do not vapor charge the Water Cooled Scroll unit. After ensuring all valves are opened and system is evacuated properly, only then start the refrigerant charging process. Also ensure that LP cutout is not by-passed during the charging process.

Step-by-step:

1. Ensure that there is no power supply to the Water Cooled Scroll unit. The liquid line solenoid needs to be kept open for the charging process and this may require a temporary power feed to it.
2. Connect the refrigerant cylinder to main service hose and purge line at the manifold end.
3. Ensure correct orientation of the refrigerant cylinder. Follow cylinder labeling/instructions so that liquid refrigerant can be charged into the system. This will be charged through the high-pressure side of the manifold and Water Cooled Scroll unit liquid service valve. Ensure that at least 70-80% of the required refrigerant charging is done by this method.
4. The compressor can then be started, and the unit continued to be charged (with the controlled liquid refrigerant through the suction service valve). The quantity of charge should always be measured. See note.
5. The system needs to be operated down to its design evaporating temperature before you can be sure the charge is correct. It is at this point that the normal refrigeration operational checks can be carried out - such as checking the liquid line sight glass for bubbles and the operating pressures.

Refrigerant charging is regarded full/complete when the operating temperature of the system has been stable for some time and the liquid line sight glass is clear.

h. Maintenance

Water Quality

Ensure that the water quality is maintained to reduce the amount of scaling inside the condenser

Electrical Connections

Check tightness of electrical connections periodically

Routine Leak Test

All joints should be checked for leaks during site visits. All joints should be leak tested once a year.

 TURN OFF OR DISCONNECT THE ELECTRICAL POWER SOURCE BEFORE CLEANING THE CONDENSER COIL OR DOING MAINTENANCE.

System Start-Up and Operational Check Sheet

Client Details

Facility/Customer Name :	
Address :	
Contact Details :	
Installer :	
Installation Date :	

Condensing Unit Info

CDU Model :	
Serial Number :	
CDU Location :	
Indoor Unit Make/Model :	

System Details

Room/Case ID :	
Pipe Length (approx.) :	
OAT @ Start-Up/Check :	
PSI Leak Test :	PSIG
Duration :	Hours
System is Leak Tight :	Y / N
Triple Evacuation :	Y / N
Micron Gauge Reading :	microns
Total Evacuation :	PSIG @ # of Hrs
Refrigerant :	
Total Charge :	Kg.
Sight Glass Clear :	Y / N
Evap Fans Running :	Y / N
Liquid Line Insulation :	Y / N
Sound and Vibration	

System Operation

COMP Voltage :	V
COMP Current :	A
Suction Pressure :	PSIG/Bar
Liquid Line Pressure :	PSIG/Bar
COMP Suction Temp :	°C
COMP Disch Temp :	°C
Liquid Line Temp :	°C
Compressor SH :	K
Subcooling :	K
Adjustable LP Setpoint :	PSIG
Design/Operating Temp:	°C
Actual Room/Case Temp :	°C
Condenser Fins :	

Comments

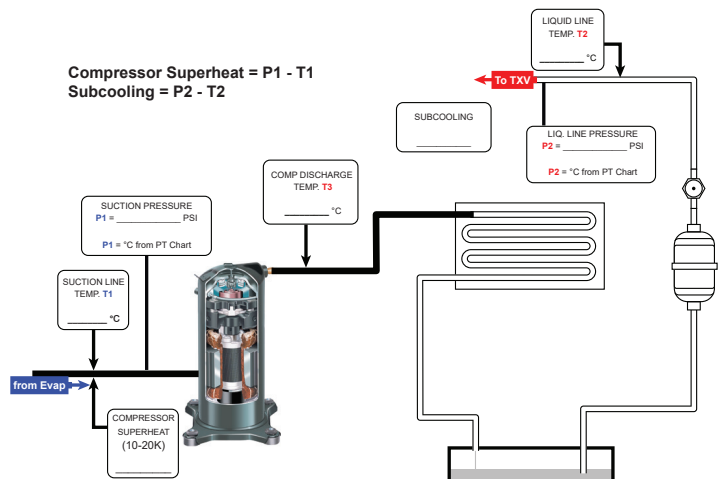

Prepared by: _____

Date: _____

Disclaimer

Technical data given was correct at the time of printing. Products, specifications and data in this literature are subject to change without prior notice. Updates will be done periodically. Should you need clarification of a specific data, value or information, kindly contact Emerson representative.

Contact list

United Arab Emirates

Jebel Ali Free Zone
P.O. Box 26382, Dubai
United Arab Emirates
Toll Free: 8000 441 3428
Tel: +971 4 8118100
Fax: +971 4 8865465

Saudi Arabia

P.O. Box 34332 - 3620
2nd Industrial City, 67 St.
Dammam, Saudi Arabia
Toll Free: 8008 443 426
Tel: +966 3 8147560
Fax: +966 3 8147570

South Africa

11 Quark Crescent
Linbro Business Park
Sandton 2065, South Africa
Toll Free: 0800 980 3711
Tel: +27 11 451 3700
Fax: +27 11 451 3800

Egypt

P.O.Box 11799
11 Mustafa Refaat Street
Sheraton, Heliopolis
Cairo, Egypt
Tel: +20 2 226 5854



EmersonMEA



EmersonMiddleEastAfrica

EmersonClimateMEA.com



EMERSON™