



技术文件

艾默生DX1是一款可以精确控制制冷剂流量以及系统过热度的电子膨胀阀，适用于冷凝机组、热泵、精密空调、交通运输工具空调等应用。

关键属性：

- 适用于R22, R134a, R404A, R410A, R32, R407C
- 冷量覆盖1.5 ~ 9冷吨（以R22作参考）
- 单对极12VDC步进电机驱动，500脉冲
- UL认证
- 高精度、精确的流量控制
- 优化的节能效果
- 整体密封式的阀体设计
- 双向应用设计，可适用于热泵
- 高可靠性



选型表：

	PCN	型号	口径 (mm)	正向开阀压差 (Bar)	反向开阀压差 (Bar)	名义制冷量 (KW)					
						R22	R410A	R134a	R407C	R32	R404A
阀体	098370	DX1-A13	1.30	35	25	5.3	6.2	4.1	5.4	10.1	3.7
	098371	DX1-A16	1.65			8.5	10	6.7	8.8	16.3	6
	098372	DX1-A18	1.80			10.3	12.1	8.1	10.6	19.7	7.3
	098373	DX1-A20	2.00			12.6	14.8	9.8	12.9	24.1	8.9
	098374	DX1-A22	2.20			15.2	17.8	11.8	15.6	28.9	10.7
	098375	DX1-A24	2.40			18	21.2	14.1	18.5	34.5	12.7
	098376	DX1-A28	2.80		15	24.6	28.9	19.2	25.2	47.1	17.3
	098377	DX1-A30	3.00			26.8	31.5	21	27.5	51.3	18.9
	098378	DX1-A32	3.20			28.9	33.9	22.6	29.6	55.2	20.3
定子	098379	DX1-SU155J	IP65, 线长 1.5M, 带 XHP-5 端子								

*名义制冷量基于 ARI 工况。

	DX1 电子膨胀阀	流体控制
	技术文件	

阀体技术参数:

流体方向	双向
流量特性	非线性
最大工作压力MWP	47 bar
爆破压力	188 bar (1分钟无破裂)
流体温度	-30 ~ 70 °C
环境温度	-30 ~ 60 °C
全开脉冲	500 (注意: 过关时建议560脉冲, 但不超过600脉冲)
开阀脉冲	30 +/- 20
寿命	10万次全开全关测试

定子技术参数:

类型	5线单极步进电机
励磁速度 (PPS)	30 ~ 90 PPS (1 PPS = 1 脉冲/秒)
供电电压	12 VDC (+/- 10%)
名义操作电流 @ 12 VDC	260 毫安/相
电阻	46 欧姆/相 (+/- 10%)
绝缘等级	E
连接线长度	1.5m, 与定子集成
防护等级	IP65

声明:

技术数据在印刷前已经校对过, 印刷之后有再更新的可能, 如有需要对某一参数确认, 请联系艾默生环境优化技术。

艾默生环境优化技术对参数中可能存在的差错概不负责, 艾默生环境优化技术保留自行改变其产品而不预先通知的权利。

本文件中的参数基于艾默生环境优化技术认为可靠的数据和测试, 并符合今天的技术需求。这些信息预期由具有合适的专业知识和技能的人员自行判断和评估风险后来使用。

励磁方式与开关阀对应关系图：

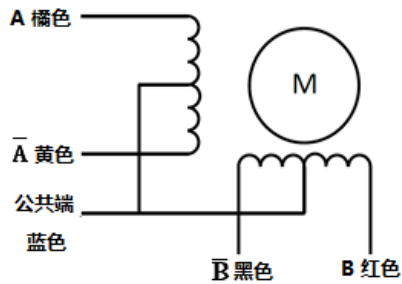

线号及颜色	阀芯运动方向							
	开阀：→				关阀：←			
A: 橘色	ON	ON	OFF	OFF	OFF	OFF	OFF	ON
B: 红色	OFF	ON	ON	ON	OFF	OFF	OFF	OFF
\bar{A} : 黄色	OFF	OFF	OFF	ON	ON	ON	OFF	OFF
\bar{B} : 黑色	OFF	OFF	OFF	OFF	OFF	ON	ON	ON
公共端: 蓝色	ON	ON	ON	ON	ON	ON	ON	ON

定子尺寸 (mm) :

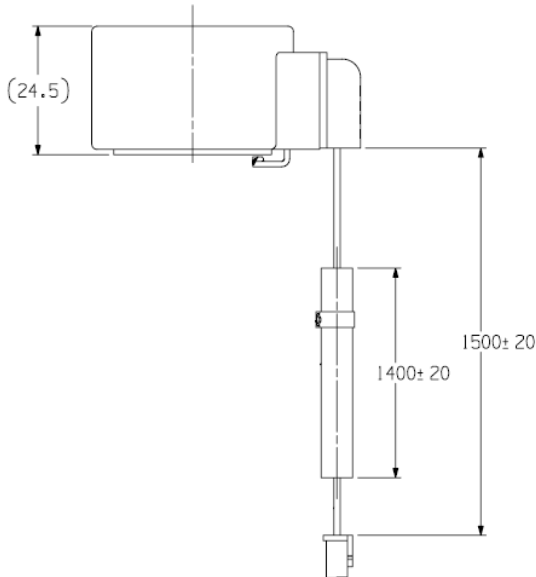

阀体尺寸 (mm) :

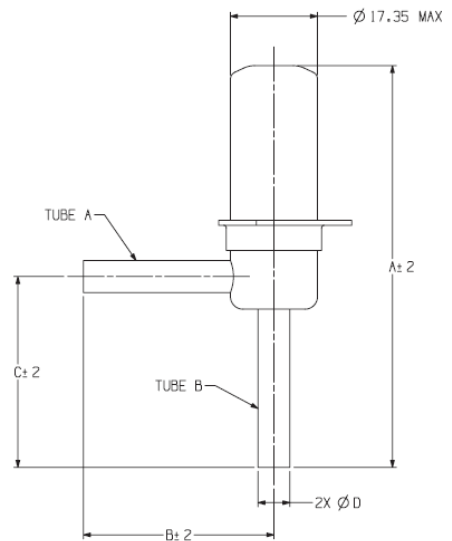

型号	口径(mm)	A(mm)	B(mm)	C(mm)	D(mm)
DX1-A13	1.30	80	38	38	6.35 +0/- 0.15
DX1-A16	1.65				
DX1-A18	1.80				
DX1-A20	2.00				
DX1-A22	2.20				
DX1-A24	2.40	89	50	47	7.94 +0.1/- 0.1
DX1-A28	2.80				8.0 +0/-0.15
DX1-A30	3.00				
DX1-A32	3.20				



DX1 电子膨胀阀

流体控制

技术文件

R22扩展冷量表:

阀体 型号	蒸发温度[°C]	15						10						5					
	冷凝温度[°C]	33.6	38.5	43.1	47.3	51.2	54.9	30.2	35.5	40.2	44.7	48.7	52.6	27	32.6	37.6	42.2	46.5	50.5
	ΔP [MPa]	0.52	0.69	0.86	1.03	1.21	1.38	0.52	0.69	0.86	1.03	1.21	1.38	0.52	0.69	0.86	1.03	1.21	1.38
DX1-A13	扩展冷量 [kW]	4.1	4.7	5.3	5.8	6.3	6.7	4.1	4.7	5.3	5.8	6.2	6.7	4.1	4.7	5.3	5.8	6.2	6.7
DX1-A16		6.6	7.6	8.5	9.3	10	10.7	6.6	7.6	8.5	9.3	10	10.7	6.5	7.5	8.4	9.2	10	10.7
DX1-A18		8	9.2	10.3	11.3	12.2	13	7.9	9.2	10.2	11.2	12.1	13	7.9	9.1	10.2	11.2	12.1	12.9
DX1-A20		9.7	11.2	12.6	13.8	14.9	15.9	9.7	11.2	12.5	13.7	14.8	15.9	9.7	11.2	12.5	13.7	14.8	15.8
DX1-A22		11.7	13.6	15.2	16.6	17.9	19.2	11.7	13.5	15.1	16.6	17.9	19.1	11.7	13.5	15.1	16.5	17.9	19.1
DX1-A24		13.9	16.1	18	19.7	21.2	22.7	13.9	16	17.9	19.6	21.2	22.7	13.8	16	17.9	19.6	21.1	22.6
DX1-A28		19	21.9	24.5	26.9	29	31	19	21.9	24.5	26.8	29	31	18.9	21.8	24.4	26.8	28.9	30.9
DX1-A30		20.7	23.9	26.7	29.3	31.6	33.8	20.7	23.9	26.7	29.2	31.6	33.7	20.6	23.8	26.6	29.2	31.5	33.7
DX1-A32		22.3	25.8	28.8	31.6	34.1	36.5	22.3	25.7	28.8	31.5	34	36.4	22.2	25.7	28.7	31.4	34	36.3
阀体 型号	蒸发温度[°C]	0						-5						-10					
	冷凝温度[°C]	24	29.9	35.1	40	44.4	48.5	21.1	27.3	32.9	37.9	42.5	46.7	18.5	25	30.8	36	40.7	45.1
	ΔP [MPa]	0.52	0.69	0.86	1.03	1.21	1.38	0.52	0.69	0.86	1.03	1.21	1.38	0.52	0.69	0.86	1.03	1.21	1.38
DX1-A13	扩展冷量 [kW]	4.1	4.7	5.2	5.7	6.2	6.6	4	4.7	5.2	5.3	6.2	6.6	4	4.6	5.2	5.7	6.1	6.6
DX1-A16		6.5	7.5	8.4	9.2	10	10.6	6.5	7.5	8.4	8.4	9.9	10.6	6.5	7.4	8.3	9.1	9.9	10.5
DX1-A18		7.9	9.1	10.2	11.2	12.1	12.9	7.9	9.1	10.1	10.2	12	12.8	7.8	9	10.1	11.1	11.9	12.8
DX1-A20		9.7	11.2	12.5	13.7	14.8	15.8	9.6	11.1	12.4	12.5	14.7	15.7	9.6	11	12.3	13.5	14.6	15.6
DX1-A22		11.7	13.5	15	16.5	17.8	19	11.6	13.4	15	15.1	17.7	18.9	11.5	13.3	14.9	16.3	17.6	18.8
DX1-A24		13.8	15.9	17.8	19.5	21.1	22.5	13.7	15.9	17.7	17.9	21	22.4	13.7	15.8	17.6	19.3	20.9	22.3
DX1-A28		18.9	21.8	24.3	26.7	28.8	30.8	18.8	21.7	24.2	24.4	28.7	30.7	18.7	21.6	24.1	26.4	28.5	30.5
DX1-A30		20.5	23.7	26.5	29.1	31.4	33.5	20.5	23.6	26.4	26.6	31.2	33.4	20.3	23.5	26.3	28.8	31.1	33.2
DX1-A32		22.2	25.6	28.6	31.3	33.8	36.2	22.1	25.5	28.5	28.7	33.7	36	21.9	25.3	28.3	31	33.5	35.8
阀体 型号	蒸发温度[°C]	-15						-20						-25					
	冷凝温度[°C]	16	22.9	28.9	34.3	39.2	43.7	21	27.2	32.7	37.8	42.4	46.6	19.2	25.7	31.4	36.5	41.2	45.6
	ΔP [MPa]	0.52	0.69	0.86	1.03	1.21	1.38	0.69	0.86	1.03	1.21	1.38	1.55	0.69	0.86	1.03	1.21	1.38	
DX1-A13	扩展冷量 [kW]	4	4.6	5.2	5.7	6.1	6.5	4.6	5.1	5.6	6.1	6.5	6.9	4.5	5.1	5.6	6	6.4	6.8
DX1-A16		6.4	7.4	8.3	9.1	9.8	10.5	7.3	8.2	9	9.7	10.4	11	7.3	8.2	8.9	9.6	10.3	10.9
DX1-A18		7.8	9	10	11	11.9	12.7	8.9	10	10.9	11.8	12.6	13.4	8.8	9.9	10.8	11.7	12.5	13.3
DX1-A20		9.5	11	12.3	13.4	14.5	15.5	10.9	12.2	13.3	14.4	15.4	16.3	10.8	12.1	13.2	14.3	15.3	16.2
DX1-A22		11.5	13.2	14.8	16.2	17.5	18.7	13.1	14.7	16.1	17.4	18.6	19.7	13	14.6	16	17.3	18.4	19.6
DX1-A24		13.6	15.7	17.5	19.2	20.7	22.2	15.6	17.4	19.1	20.6	22	23.3	15.4	17.3	18.9	20.4	21.8	23.2
DX1-A28		18.6	21.4	24	26.3	28.4	30.3	21.3	23.8	26	28.1	30.1	31.9	21.1	23.6	25.8	27.9	29.8	31.7
DX1-A30		20.2	23.4	26.1	28.6	30.9	33	23.2	25.9	28.4	30.7	32.8	34.8	23	25.7	28.2	30.4	32.5	34.5
DX1-A32		21.8	25.2	28.2	30.8	33.3	35.6	25	27.9	30.6	33.1	35.3	37.5	24.8	27.7	30.4	32.8	35.1	37.2
阀体 型号	蒸发温度[°C]	-30						-35						-40					
	冷凝温度[°C]	17.7	24.4	30.2	35.5	40.2	44.7	16.4	23.2	29.2	34.5	39.4	43.9	15.2	22.2	28.3	33.7	38.7	43.2
	ΔP [MPa]	0.69	0.86	1.03	1.21	1.38	1.55	0.69	0.86	1.03	1.21	1.38	1.55	0.69	0.86	1.03	1.21	1.38	
DX1-A13	扩展冷量 [kW]	4.5	5	5.5	6	6.4	6.8	4.5	5	5.5	5.9	6.3	6.7	4.4	4.9	5.4	5.8	6.2	6.6
DX1-A16		7.2	8.1	8.8	9.6	10.2	10.8	7.2	8	8.8	9.5	10.1	10.7	7.1	7.9	8.7	9.4	10	10.6
DX1-A18		8.8	9.8	10.7	11.6	12.4	13.1	8.7	9.7	10.6	11.5	12.3	13	8.6	9.6	10.5	11.4	12.1	12.9
DX1-A20		10.7	12	13.1	14.2	15.1	16.1	10.6	11.9	13	14	15	15.9	10.5	11.7	12.9	13.9	14.9	15.8
DX1-A22		12.9	14.4	15.8	17.1	18.3	19.4	12.8	14.3	15.7	16.9	18.1	19.2	12.7	14.2	15.5	16.8	17.9	19
DX1-A24		15.3	17.1	18.7	20.2	21.6	22.9	15.2	16.9	18.6	20.1	21.4	22.7	15	16.8	18.4	19.8	21.2	22.5
DX1-A28		20.9	23.4	25.6	27.7	29.6	31.4	20.7	23.2	25.4	27.4	29.3	31.1	20.5	22.9	25.1	27.1	29	30.8
DX1-A30		22.8	25.5	27.9	30.1	32.2	34.2	22.6	25.2	27.6	29.9	31.9	33.9	22.3	25	27.4	29.6	31.6	33.5
DX1-A32		24.6	27.5	30.1	32.5	34.7	36.8	24.3	27.2	29.8	32.2	34.4	36.5	24.1	26.9	29.5	31.9	34.1	36.1



DX1 电子膨胀阀

流体控制

技术文件

R407C扩展冷量表:

阀体 型号	蒸发温度[°C]	15						10						5					
	冷凝温度[°C]	31.6	36.1	40.3	44.2	47.8	51.2	28.1	32.9	37.3	41.4	45.2	48.8	24.8	29.9	34.6	38.8	42.8	46.5
	ΔP [MPa]	0.52	0.69	0.86	1.03	1.21	1.38	0.52	0.69	0.86	1.03	1.21	1.38	0.52	0.69	0.86	1.03	1.21	1.38
DX1-A13	扩展冷量 [kW]	4.1	4.7	5.3	5.8	6.3	6.7	4.1	4.7	5.3	5.8	6.2	6.7	4.1	4.7	5.2	5.7	6.2	6.6
DX1-A16		6.7	7.7	8.6	9.4	10.2	10.9	6.6	7.7	8.6	9.4	10.1	10.8	6.6	7.6	8.5	9.3	10.1	10.8
DX1-A18		8	9.3	10.4	11.4	12.3	13.1	8	9.2	10.3	11.3	12.2	13.1	8	9.2	10.3	11.3	12.2	13
DX1-A20		9.8	11.3	12.6	13.8	14.9	16	9.7	11.2	12.6	13.8	14.9	15.9	9.7	11.2	12.5	13.7	14.8	15.8
DX1-A22		11.8	13.6	15.3	16.7	18.1	19.3	11.8	13.6	15.2	16.7	18	19.2	11.7	13.5	15.1	16.6	17.9	19.1
DX1-A24		14	16.2	18.1	19.8	21.4	22.9	14	16.1	18	19.7	21.3	22.8	13.9	16	17.9	19.6	21.2	22.7
DX1-A28		19.1	22	24.7	27	29.2	31.2	19	22	24.6	26.9	29.1	31.1	18.9	21.9	24.4	26.8	28.9	30.9
DX1-A30		20.8	24.1	26.9	29.5	31.8	34	20.8	24	26.8	29.4	31.7	33.9	20.7	23.8	26.7	29.2	31.5	33.7
DX1-A32		22.4	25.9	29	31.7	34.3	36.6	22.3	25.8	28.8	31.6	34.1	36.5	22.2	25.7	28.7	31.4	34	36.3
阀体 型号	蒸发温度[°C]	0						-5						-10					
	冷凝温度[°C]	21.6	27	32	36.4	40.6	44.5	18.6	24.4	29.5	34.2	38.5	42.5	15.8	21.9	27.3	32.2	36.7	40.8
	ΔP [MPa]	0.52	0.69	0.86	1.03	1.21	1.38	0.52	0.69	0.86	1.03	1.21	1.38	0.52	0.69	0.86	1.03	1.21	1.38
DX1-A13	扩展冷量 [kW]	4	4.7	5.2	5.7	6.2	6.6	4	4.6	5.2	5.7	6.1	6.5	4	4.6	5.1	5.6	6.1	6.5
DX1-A16		6.6	7.6	8.5	9.3	10	10.7	6.5	7.5	8.4	9.2	10	10.6	6.5	7.5	8.3	9.1	9.9	10.6
DX1-A18		7.9	9.1	10.2	11.2	12.1	12.9	7.9	9.1	10.1	11.1	12	12.8	7.8	9	10.1	11	11.9	12.7
DX1-A20		9.6	11.1	12.4	13.6	14.7	15.7	9.6	11	12.3	13.5	14.6	15.6	9.5	10.9	12.2	13.4	14.5	15.5
DX1-A22		11.6	13.4	15	16.5	17.8	19	11.6	13.3	14.9	16.3	17.7	18.9	11.5	13.2	14.8	16.2	17.5	18.7
DX1-A24		13.8	15.9	17.8	19.5	21.1	22.5	13.7	15.8	17.7	19.4	20.9	22.4	13.6	15.7	17.5	19.2	20.8	22.2
DX1-A28		18.8	21.7	24.3	26.6	28.7	30.7	18.7	21.6	24.1	26.4	28.5	30.5	18.5	21.4	23.9	26.2	28.3	30.2
DX1-A30		20.5	23.7	26.5	29	31.4	33.5	20.4	23.5	26.3	28.8	31.1	33.3	20.2	23.3	26.1	28.6	30.9	33
DX1-A32		22.1	25.5	28.5	31.2	33.7	36.1	21.9	25.3	28.3	31	33.5	35.8	21.8	25.1	28.1	30.8	33.2	35.5
阀体 型号	蒸发温度[°C]	-15						-20						-25					
	冷凝温度[°C]	13.2	19.6	25.3	30.4	35	39.2	17.6	23.5	28.7	33.5	37.8	41.9	15.7	21.8	27.2	32.1	36.6	40.8
	ΔP [MPa]	0.52	0.69	0.86	1.03	1.21	1.38	0.69	0.86	1.03	1.21	1.38	1.55	0.69	0.86	1.03	1.21	1.38	1.55
DX1-A13	扩展冷量 [kW]	3.9	4.5	5.1	5.6	6	6.4	4.5	5	5.5	5.9	6.4	6.7	4.4	5	5.4	5.9	6.3	6.7
DX1-A16		6.4	7.4	8.3	9.1	9.8	10.5	7.3	8.2	9	9.7	10.4	11	7.2	8.1	8.9	9.6	10.2	10.9
DX1-A18		7.7	8.9	10	10.9	11.8	12.6	8.8	9.9	10.8	11.7	12.5	13.2	8.7	9.8	10.7	11.5	12.3	13.1
DX1-A20		9.4	10.8	12.1	13.3	14.3	15.3	10.7	12	13.1	14.2	15.2	16.1	10.6	11.9	13	14	15	15.9
DX1-A22		11.4	13.1	14.7	16.1	17.3	18.5	13	14.5	15.9	17.2	18.4	19.5	12.8	14.4	15.7	17	18.2	19.3
DX1-A24		13.5	15.5	17.4	19	20.6	22	15.4	17.2	18.9	20.4	21.8	23.1	15.2	17	18.6	20.1	21.5	22.8
DX1-A28		18.3	21.2	23.7	25.9	28	29.9	21	23.4	25.7	27.7	29.7	31.4	20.7	23.2	25.4	27.4	29.3	31.1
DX1-A30		20	23.1	25.8	28.3	30.6	32.7	22.9	25.6	28	30.3	32.4	34.3	22.6	25.3	27.7	29.9	32	33.9
DX1-A32		21.5	24.9	27.8	30.5	32.9	35.2	24.6	27.5	30.2	32.6	34.8	36.9	24.4	27.2	29.8	32.2	34.4	36.5
阀体 型号	蒸发温度[°C]	-30						-35						-40					
	冷凝温度[°C]	14.1	20.4	26	31	35.5	39.8	12.7	19.1	24.8	30	34.6	38.9	11.4	18	23.9	29.1	33.8	38.2
	ΔP [MPa]	0.69	0.86	1.03	1.21	1.38	1.55	0.69	0.86	1.03	1.21	1.38	1.55	0.69	0.86	1.03	1.21	1.38	1.55
DX1-A13	扩展冷量 [kW]	4.4	4.9	5.4	5.8	6.2	6.6	4.3	4.8	5.3	5.7	6.1	6.5	4.3	4.8	5.2	5.7	6	6.4
DX1-A16		7.1	8	8.8	9.5	10.1	10.7	7.1	7.9	8.6	9.3	10	10.6	7	7.8	8.5	9.2	9.8	10.4
DX1-A18		8.6	9.6	10.5	11.4	12.2	12.9	8.5	9.5	10.4	11.3	12	12.8	8.4	9.4	10.3	11.1	11.9	12.6
DX1-A20		10.5	11.7	12.8	13.9	14.8	15.7	10.4	11.6	12.7	13.7	14.6	15.5	10.2	11.4	12.5	13.5	14.4	15.3
DX1-A22		12.7	14.2	15.5	16.8	17.9	19	12.5	14	15.3	16.6	17.7	18.8	12.3	13.8	15.1	16.3	17.5	18.5
DX1-A24		15	16.8	18.4	19.9	21.3	22.5	14.8	16.6	18.2	19.6	21	22.3	14.6	16.4	17.9	19.4	20.7	22
DX1-A28		20.5	22.9	25.1	27.1	29	30.7	20.2	22.6	24.8	26.7	28.6	30.3	19.9	22.3	24.4	26.4	28.2	29.9
DX1-A30		22.3	25	27.4	29.6	31.6	33.5	22.1	24.7	27	29.2	31.2	33.1	21.8	24.3	26.7	28.8	30.8	32.6
DX1-A32		24	26.9	29.5	31.8	34	36.1	23.7	26.6	29.1	31.4	33.6	35.6	23.4	26.2	28.7	31	33.1	35.1



DX1 电子膨胀阀

流体控制

技术文件

R410A扩展冷量表:

阀体 型号	蒸发温度[°C]	15						10						5					
	冷凝温度[°C]	28.3	33.9	38.9	43.5	47.7	51.7	24.6	30.5	35.9	40.7	45.1	49.3	21	27.4	33	38.1	42.7	47
	ΔP [MPa]	0.55	0.83	1.1	1.38	1.65	1.93	0.55	0.83	1.1	1.38	1.65	1.93	0.55	0.83	1.1	1.38	1.65	1.93
DX1-A13	扩展冷量 [kW]	3.9	4.8	5.5	6.2	6.8	7.3	3.9	4.8	5.6	6.2	6.8	7.3	3.9	4.8	5.6	6.2	6.8	7.4
DX1-A16		6.3	7.7	8.9	10	10.9	11.8	6.3	7.8	9	10	11	11.8	6.3	7.8	9	10	11	11.9
DX1-A18		7.6	9.4	10.8	12.1	13.2	14.3	7.7	9.4	10.8	12.1	13.3	14.3	7.7	9.4	10.9	12.1	13.3	14.4
DX1-A20		9.3	11.4	13.2	14.8	16.2	17.5	9.4	11.5	13.3	14.8	16.2	17.5	9.4	11.5	13.3	14.8	16.3	17.6
DX1-A22		11.2	13.8	15.9	17.8	19.5	21	11.3	13.8	15.9	17.8	19.5	21.1	11.3	13.8	16	17.8	19.5	21.1
DX1-A24		13.4	16.4	18.9	21.2	23.2	25.1	13.4	16.4	19	21.2	23.3	25.1	13.4	16.5	19	21.3	23.3	25.1
DX1-A28		18.3	22.4	25.8	28.9	31.6	34.2	18.3	22.4	25.9	28.9	31.7	34.2	18.3	22.4	25.9	29	31.7	34.3
DX1-A30		19.9	24.4	28.1	31.5	34.5	37.2	20	24.4	28.2	31.5	34.6	37.3	20	24.5	28.2	31.6	34.6	37.4
DX1-A32		21.4	26.2	30.3	33.9	37.1	40.1	21.5	26.3	30.4	33.9	37.2	40.2	21.5	26.3	30.4	34	37.2	40.2
阀体 型号	蒸发温度[°C]	0						-5						-10					
	冷凝温度[°C]	17.5	24.3	30.3	35.7	40.5	45	14.3	21.5	27.8	33.4	38.4	43.1	11.2	18.8	25.5	31.3	36.6	41.3
	ΔP [MPa]	0.55	0.83	1.1	1.38	1.65	1.93	0.55	0.83	1.1	1.38	1.65	1.93	0.55	0.83	1.1	1.38	1.65	1.93
DX1-A13	扩展冷量 [kW]	3.9	4.8	5.6	6.2	6.8	7.4	3.9	4.8	5.5	6.2	6.8	7.3	3.9	4.8	5.5	6.2	6.8	7.3
DX1-A16		6.3	7.8	9	10	11	11.9	6.3	7.8	8.9	10	11	11.8	6.3	7.7	8.9	10	10.9	11.8
DX1-A18		7.7	9.4	10.9	12.1	13.3	14.4	7.7	9.4	10.8	12.1	13.3	14.3	7.6	9.4	10.8	12.1	13.2	14.3
DX1-A20		9.4	11.5	13.3	14.8	16.3	17.6	9.4	11.5	13.2	14.8	16.2	17.5	9.3	11.4	13.2	14.8	16.2	17.5
DX1-A22		11.3	13.8	16	17.8	19.5	21.1	11.3	13.8	15.9	17.8	19.5	21.1	11.2	13.8	15.9	17.8	19.5	21
DX1-A24		13.4	16.5	19	21.3	23.3	25.1	13.4	16.4	19	21.2	23.2	25.1	13.4	16.4	18.9	21.1	23.2	25
DX1-A28		18.3	22.4	25.9	29	31.7	34.3	18.3	22.4	25.9	28.9	31.7	34.2	18.2	22.3	25.8	28.8	31.6	34.1
DX1-A30		20	24.5	28.2	31.6	34.6	37.4	19.9	24.4	28.2	31.5	34.5	37.3	19.9	24.3	28.1	31.4	34.4	37.2
DX1-A32		21.5	26.3	30.4	34	37.2	40.2	21.5	26.3	30.3	33.9	37.2	40.1	21.4	26.2	30.2	33.8	37	40
阀体 型号	蒸发温度[°C]	-15						-20						-25					
	冷凝温度[°C]	8.3	16.4	23.3	29.4	34.8	39.8	14.1	21.4	27.7	33.3	38.4	43	12.1	19.7	26.2	31.9	37.1	41.9
	ΔP [MPa]	0.55	0.83	1.1	1.38	1.65	1.93	0.83	1.1	1.38	1.65	1.93	2.21	0.83	1.1	1.38	1.65	1.93	2.21
DX1-A13	扩展冷量 [kW]	3.9	4.8	5.5	6.2	6.7	7.3	4.7	5.5	6.1	6.7	7.3	7.8	4.7	5.4	6.1	6.7	7.2	7.7
DX1-A16		6.3	7.7	8.9	9.9	10.9	11.8	7.7	8.8	9.9	10.8	11.7	12.5	7.6	8.8	9.8	10.8	11.6	12.4
DX1-A18		7.6	9.3	10.8	12	13.2	14.2	9.3	10.7	12	13.1	14.1	15.1	9.2	10.6	11.9	13	14.1	15
DX1-A20		9.3	11.4	13.2	14.7	16.1	17.4	11.3	13.1	14.6	16	17.3	18.5	11.3	13	14.5	15.9	17.2	18.4
DX1-A22		11.2	13.7	15.8	17.7	19.4	20.9	13.6	15.7	17.6	19.3	20.8	22.3	13.5	15.6	17.5	19.2	20.7	22.1
DX1-A24		13.3	16.3	18.8	21.1	23.1	24.9	16.2	18.7	21	23	24.8	26.5	16.1	18.6	20.8	22.8	24.6	26.3
DX1-A28		18.2	22.2	25.7	28.7	31.5	34	22.1	25.5	28.6	31.3	33.8	36.1	22	25.4	28.4	31.1	33.6	35.9
DX1-A30		19.8	24.2	28	31.3	34.3	37	24.1	27.8	31.1	34.1	36.8	39.4	24	27.7	30.9	33.9	36.6	39.1
DX1-A32		21.3	26.1	30.1	33.7	36.9	39.9	26	30	33.5	36.7	39.6	42.4	25.8	29.8	33.3	36.5	39.4	42.1
阀体 型号	蒸发温度[°C]	-30						-35						-40					
	冷凝温度[°C]	10.3	18.1	24.8	30.7	36	40.9	8.7	16.7	23.7	29.7	35.1	40	7.3	15.6	22.6	28.8	34.3	39.3
	ΔP [MPa]	0.83	1.1	1.38	1.65	1.93	2.21	0.83	1.1	1.38	1.65	1.93	2.21	0.83	1.1	1.38	1.65	1.93	2.21
DX1-A13	扩展冷量 [kW]	4.7	5.4	6	6.6	7.2	7.6	4.6	5.4	6	6.6	7.1	7.6	4.6	5.3	5.9	6.5	7	7.5
DX1-A16		7.6	8.7	9.7	10.7	11.5	12.3	7.5	8.7	9.7	10.6	11.4	12.2	7.4	8.6	9.6	10.5	11.3	12.1
DX1-A18		9.1	10.6	11.8	12.9	14	14.9	9.1	10.5	11.7	12.8	13.9	14.8	9	10.4	11.6	12.7	13.7	14.7
DX1-A20		11.2	12.9	14.4	15.8	17.1	18.3	11.1	12.8	14.3	15.7	16.9	18.1	11	12.7	14.2	15.5	16.8	17.9
DX1-A22		13.4	15.5	17.4	19	20.5	22	13.3	15.4	17.2	18.9	20.4	21.8	13.2	15.3	17.1	18.7	20.2	21.6
DX1-A24		16	18.5	20.7	22.6	24.5	26.1	15.9	18.3	20.5	22.5	24.3	25.9	15.7	18.2	20.3	22.3	24	25.7
DX1-A28		21.8	25.2	28.2	30.9	33.3	35.6	21.7	25	28	30.6	33.1	35.4	21.5	24.8	27.7	30.3	32.8	35
DX1-A30		23.8	27.5	30.7	33.6	36.3	38.8	23.6	27.3	30.5	33.4	36.1	38.5	23.4	27	30.2	33.1	35.7	38.2
DX1-A32		25.6	29.6	33.1	36.2	39.1	41.8	25.4	29.3	32.8	35.9	38.8	41.5	25.2	29.1	32.5	35.6	38.4	41.1



技术文件

R134a扩展冷量表:

阀体 型号	蒸发温度[°C]	15						10						5					
	冷凝温度[°C]	35.6	40.9	43.3	45.6	49.9	53.9	32.6	38.1	40.7	43.1	47.7	51.8	29.7	35.6	38.3	40.8	45.6	49.9
	ΔP [MPa]	0.41	0.55	0.62	0.69	0.83	0.97	0.41	0.55	0.62	0.69	0.83	0.97	0.41	0.55	0.62	0.69	0.83	0.97
DX1-A13	扩展冷量 [kW]	3.4	4	4.2	4.4	4.8	5.2	3.4	3.9	4.2	4.4	4.8	5.2	3.4	3.9	4.1	4.4	4.8	5.1
DX1-A16		5.6	6.5	6.9	7.2	7.9	8.6	5.6	6.4	6.8	7.2	7.9	8.5	5.5	6.4	6.7	7.1	7.8	8.4
DX1-A18		6.8	7.8	8.3	8.7	9.6	10.3	6.7	7.8	8.2	8.7	9.5	10.3	6.7	7.7	8.2	8.6	9.4	10.2
DX1-A20		8.2	9.5	10	10.6	11.6	12.5	8.1	9.4	10	10.5	11.5	12.4	8.1	9.3	9.9	10.4	11.4	12.3
DX1-A22		9.9	11.4	12.1	12.7	14	15.1	9.8	11.3	12	12.6	13.8	15	9.7	11.2	11.9	12.5	13.7	14.8
DX1-A24		11.8	13.6	14.4	15.2	16.7	18	11.7	13.5	14.3	15.1	16.5	17.9	11.6	13.4	14.2	15	16.4	17.7
DX1-A28		16.1	18.5	19.7	20.7	22.7	24.5	15.9	18.4	19.5	20.6	22.5	24.3	15.8	18.2	19.3	20.4	22.3	24.1
DX1-A30		17.6	20.3	21.5	22.7	24.8	26.8	17.4	20.1	21.3	22.5	24.6	26.6	17.3	19.9	21.1	22.3	24.4	26.4
DX1-A32		18.9	21.8	23.1	24.4	26.7	28.9	18.7	21.6	23	24.2	26.5	28.6	18.6	21.5	22.8	24	26.3	28.4
阀体 型号	蒸发温度[°C]	0						-5						-10					
	冷凝温度[°C]	27	33.2	36.1	38.7	43.7	48.2	24.6	31.1	34.1	36.8	41.9	46.6	22.3	29.2	35.1	40.4	45.2	49.6
	ΔP [MPa]	0.41	0.55	0.62	0.69	0.83	0.97	0.41	0.55	0.62	0.69	0.83	0.97	0.41	0.55	0.69	0.83	0.97	1.1
DX1-A13	扩展冷量 [kW]	3.3	3.9	4.1	4.3	4.7	5.1	3.3	3.8	4.3	4.7	5	5.4	3.3	3.8	4.2	4.6	5	5.3
DX1-A16		5.5	6.3	6.7	7	7.7	8.3	5.4	6.2	7	7.6	8.2	8.8	5.3	6.2	6.9	7.5	8.1	8.7
DX1-A18		6.6	7.6	8.1	8.5	9.3	10.1	6.5	7.5	8.4	9.2	10	10.7	6.4	7.4	8.3	9.1	9.8	10.5
DX1-A20		8	9.2	9.8	10.3	11.3	12.2	7.9	9.1	10.2	11.2	12.1	12.9	7.8	9	10.1	11	11.9	12.7
DX1-A22		9.6	11.1	11.8	12.4	13.6	14.7	9.5	11	12.3	13.4	14.5	15.5	9.4	10.8	12.1	13.3	14.3	15.3
DX1-A24		11.5	13.3	14.1	14.8	16.2	17.5	11.4	13.1	14.7	16.1	17.3	18.5	11.2	13	14.5	15.9	17.1	18.3
DX1-A28		15.6	18	19.1	20.2	22.1	23.9	15.5	17.9	20	21.9	23.6	25.2	15.3	17.6	19.7	21.6	23.3	24.9
DX1-A30		17.1	19.7	20.9	22.1	24.2	26.1	16.9	19.5	21.8	23.9	25.8	27.6	16.7	19.3	21.6	23.6	25.5	27.3
DX1-A32		18.4	21.2	22.5	23.8	26	28.1	18.2	21	23.5	25.7	27.8	29.7	18	20.8	23.2	25.4	27.5	29.4
阀体 型号	蒸发温度[°C]	-15						-20						-25					
	冷凝温度[°C]	20.3	27.5	33.6	39.1	44	48.4	18.5	25.9	32.3	37.9	42.9	47.5	17	24.6	31.1	36.9	42	46.6
	ΔP [MPa]	0.41	0.55	0.69	0.83	0.97	1.1	0.41	0.55	0.69	0.83	0.97	1.1	0.41	0.55	0.69	0.83	0.97	1.1
DX1-A13	扩展冷量 [kW]	3.2	3.7	4.2	4.6	4.9	5.3	3.2	3.7	4.1	4.5	4.9	5.2	3.1	3.6	4	4.4	4.8	5.1
DX1-A16		5.3	6.1	6.8	7.4	8	8.6	5.2	6	6.7	7.3	7.9	8.5	5.1	5.9	6.6	7.2	7.8	8.4
DX1-A18		6.4	7.3	8.2	9	9.7	10.4	6.3	7.2	8.1	8.9	9.6	10.2	6.2	7.1	8	8.7	9.4	10.1
DX1-A20		7.7	8.9	9.9	10.9	11.8	12.6	7.6	8.8	9.8	10.7	11.6	12.4	7.5	8.6	9.7	10.6	11.4	12.2
DX1-A22		9.3	10.7	12	13.1	14.2	15.1	9.1	10.6	11.8	12.9	14	14.9	9	10.4	11.6	12.7	13.8	14.7
DX1-A24		11.1	12.8	14.3	15.7	16.9	18.1	10.9	12.6	14.1	15.4	16.7	17.8	10.8	12.4	13.9	15.2	16.4	17.6
DX1-A28		15.1	17.4	19.5	21.3	23	24.6	14.9	17.2	19.2	21	22.7	24.3	14.7	16.9	18.9	20.7	22.4	23.9
DX1-A30		16.5	19	21.3	23.3	25.2	26.9	16.3	18.8	21	23	24.8	26.6	16	18.5	20.7	22.7	24.5	26.2
DX1-A32		17.8	20.5	22.9	25.1	27.1	29	17.5	20.2	22.6	24.8	26.7	28.6	17.3	19.9	22.3	24.4	26.4	28.2
阀体 型号	蒸发温度[°C]	-30						-35						-40					
	冷凝温度[°C]	15.6	23.5	30.2	36	41.2	45.9	22.5	29.3	35.3	40.5	45.3	49.7	21.7	28.6	34.7	40	44.8	49.2
	ΔP [MPa]	0.41	0.55	0.69	0.83	0.97	1.1	0.55	0.69	0.83	0.97	1.1	1.24	0.55	0.69	0.83	0.97	1.1	1.24
DX1-A13	扩展冷量 [kW]	3.1	3.6	4	4.4	4.7	5	3	3.5	3.9	4.3	4.6	5	3	3.4	3.9	4.2	4.6	4.9
DX1-A16		5	5.8	6.5	7.1	7.7	8.2	5	5.7	6.4	7	7.6	8.1	4.9	5.6	6.3	6.9	7.4	8
DX1-A18		6.1	7	7.9	8.6	9.3	9.9	6	6.9	7.7	8.5	9.2	9.8	5.9	6.8	7.6	8.3	9	9.6
DX1-A20		7.4	8.5	9.5	10.4	11.2	12	7.3	8.4	9.4	10.3	11.1	11.8	7.1	8.2	9.2	10.1	10.9	11.6
DX1-A22		8.9	10.2	11.4	12.5	13.5	14.5	8.7	10.1	11.3	12.3	13.3	14.3	8.6	9.9	11.1	12.1	13.1	14
DX1-A24		10.6	12.2	13.7	15	16.2	17.3	10.4	12	13.5	14.8	15.9	17	10.3	11.8	13.2	14.5	15.7	16.8
DX1-A28		14.4	16.7	18.6	20.4	22	23.6	14.2	16.4	18.3	20.1	21.7	23.2	14	16.1	18	19.8	21.3	22.8
DX1-A30		15.8	18.2	20.4	22.3	24.1	25.8	15.5	17.9	20.1	22	23.7	25.4	15.3	17.6	19.7	21.6	23.3	25
DX1-A32		17	19.6	21.9	24	25.9	27.7	16.7	19.3	21.6	23.7	25.5	27.3	16.4	19	21.2	23.3	25.1	26.9



DX1 电子膨胀阀

流体控制

技术文件

R404A扩展冷量表:

阀体 型号	蒸发温度[°C]	15						10						5					
	冷凝温度[°C]	31.2	35.6	39.7	43.5	47.1	50.4	27.6	32.4	36.7	40.7	44.5	48	24.2	29.3	33.9	38.1	42	45.7
	ΔP [MPa]	0.52	0.69	0.86	1.03	1.21	1.38	0.52	0.69	0.86	1.03	1.21	1.38	0.52	0.69	0.86	1.03	1.21	1.38
DX1-A13	扩展冷量 [kW]	2.7	3.1	3.4	3.8	4.1	4.3	2.6	3.1	3.4	3.7	4	4.3	2.6	3	3.4	3.7	4	4.3
DX1-A16		4.3	5	5.6	6.1	6.6	7	4.3	4.9	5.5	6.1	6.5	7	4.3	4.9	5.5	6	6.5	6.9
DX1-A18		5.2	6.1	6.8	7.4	8	8.6	5.2	6	6.7	7.4	8	8.5	5.2	6	6.7	7.3	7.9	8.5
DX1-A20		6.4	7.4	8.3	9	9.8	10.4	6.4	7.3	8.2	9	9.7	10.4	6.3	7.3	8.1	8.9	9.6	10.3
DX1-A22		7.7	8.9	9.9	10.9	11.7	12.6	7.6	8.8	9.9	10.8	11.7	12.5	7.6	8.8	9.8	10.7	11.6	12.4
DX1-A24		9.1	10.5	11.8	12.9	13.9	14.9	9.1	10.5	11.7	12.8	13.9	14.8	9	10.4	11.6	12.7	13.8	14.7
DX1-A28		12.4	14.4	16.1	17.6	19	20.3	12.4	14.3	16	17.5	18.9	20.2	12.3	14.2	15.8	17.4	18.7	20
DX1-A30		13.6	15.7	17.5	19.2	20.7	22.2	13.5	15.6	17.4	19.1	20.6	22	13.4	15.5	17.3	19	20.5	21.9
DX1-A32	14.6	16.8	18.8	20.6	22.3	23.8	14.5	16.7	18.7	20.5	22.1	23.7	14.4	16.6	18.6	20.4	22	23.5	
阀体 型号	蒸发温度[°C]	0						-5						-10					
	冷凝温度[°C]	21	26.3	31.2	35.6	39.7	43.5	17.9	23.6	28.7	33.3	37.6	41.5	15	21	26.4	31.2	35.7	39.7
	ΔP [MPa]	0.52	0.69	0.86	1.03	1.21	1.38	0.52	0.69	0.86	1.03	1.21	1.38	0.52	0.69	0.86	1.03	1.21	1.38
DX1-A13	扩展冷量 [kW]	2.6	3	3.4	3.7	4	4.2	2.6	3	3.3	3.6	3.9	4.2	2.5	2.9	3.3	3.6	3.9	4.2
DX1-A16		4.2	4.9	5.4	6	6.4	6.9	4.2	4.8	5.4	5.9	6.4	6.8	4.1	4.8	5.3	5.8	6.3	6.7
DX1-A18		5.1	5.9	6.6	7.3	7.8	8.4	5.1	5.9	6.6	7.2	7.8	8.3	5	5.8	6.5	7.1	7.7	8.2
DX1-A20		6.3	7.2	8.1	8.8	9.6	10.2	6.2	7.2	8	8.8	9.5	10.1	6.1	7.1	7.9	8.7	9.4	10
DX1-A22		7.5	8.7	9.7	10.6	11.5	12.3	7.4	8.6	9.6	10.5	11.4	12.2	7.4	8.5	9.5	10.4	11.2	12
DX1-A24		8.9	10.3	11.5	12.6	13.6	14.6	8.8	10.2	11.4	12.5	13.5	14.4	8.7	10.1	11.3	12.4	13.3	14.3
DX1-A28		12.2	14	15.7	17.2	18.6	19.9	12	13.9	15.5	17	18.4	19.7	11.9	13.7	15.4	16.8	18.2	19.4
DX1-A30		13.3	15.3	17.2	18.8	20.3	21.7	13.2	15.2	17	18.6	20.1	21.5	13	15	16.8	18.4	19.9	21.2
DX1-A32	14.3	16.5	18.4	20.2	21.8	23.3	14.1	16.3	18.2	20	21.6	23.1	14	16.1	18	19.7	21.3	22.8	
阀体 型号	蒸发温度[°C]	-15						-20						-25					
	冷凝温度[°C]	12.4	18.7	24.3	29.3	33.9	38.1	16.5	22.3	27.6	32.3	36.6	40.7	14.6	20.6	26	30.9	35.3	39.4
	ΔP [MPa]	0.52	0.69	0.86	1.03	1.21	1.38	0.69	0.86	1.03	1.21	1.38	1.55	0.69	0.86	1.03	1.21	1.38	1.55
DX1-A13	扩展冷量 [kW]	2.5	2.9	3.2	3.6	3.8	4.1	2.9	3.2	3.5	3.8	4	4.3	2.8	3.2	3.5	3.7	4	4.2
DX1-A16		4.1	4.7	5.3	5.8	6.2	6.7	4.6	5.2	5.7	6.1	6.6	7	4.6	5.1	5.6	6	6.5	6.9
DX1-A18		5	5.7	6.4	7	7.6	8.1	5.6	6.3	6.9	7.5	8	8.5	5.6	6.2	6.8	7.4	7.9	8.3
DX1-A20		6	7	7.8	8.5	9.2	9.9	6.9	7.7	8.4	9.1	9.7	10.3	6.8	7.6	8.3	9	9.6	10.2
DX1-A22		7.3	8.4	9.4	10.3	11.1	11.9	8.3	9.2	10.1	10.9	11.7	12.4	8.2	9.1	10	10.8	11.5	12.2
DX1-A24		8.6	10	11.1	12.2	13.2	14.1	9.8	11	12	13	13.9	14.7	9.7	10.8	11.8	12.8	13.7	14.5
DX1-A28		11.7	13.6	15.2	16.6	17.9	19.2	13.4	15	16.4	17.7	18.9	20.1	13.2	14.7	16.1	17.4	18.6	19.8
DX1-A30		12.8	14.8	16.6	18.2	19.6	21	14.6	16.3	17.9	19.3	20.7	21.9	14.4	16.1	17.6	19	20.4	21.6
DX1-A32	13.8	15.9	17.8	19.5	21.1	22.5	15.7	17.5	19.2	20.8	22.2	23.5	15.5	17.3	18.9	20.5	21.9	23.2	
阀体 型号	蒸发温度[°C]	-30						-35						-40					
	冷凝温度[°C]	12.8	19.1	24.6	29.6	34.2	38.4	11.3	17.7	23.4	28.5	33.2	37.4	9.9	16.5	22.4	27.6	32.3	36.6
	ΔP [MPa]	0.69	0.86	1.03	1.21	1.38	1.55	0.69	0.86	1.03	1.21	1.38	1.55	0.69	0.86	1.03	1.21	1.38	1.55
DX1-A13	扩展冷量 [kW]	2.8	3.1	3.4	3.7	3.9	4.2	2.7	3	3.3	3.6	3.9	4.1	2.7	3	3.3	3.5	3.8	4
DX1-A16		4.5	5	5.5	5.9	6.4	6.7	4.4	4.9	5.4	5.9	6.3	6.6	4.3	4.9	5.3	5.7	6.1	6.5
DX1-A18		5.5	6.1	6.7	7.2	7.7	8.2	5.4	6	6.6	7.1	7.6	8.1	5.3	5.9	6.5	7	7.5	7.9
DX1-A20		6.7	7.5	8.2	8.8	9.4	10	6.6	7.3	8	8.7	9.3	9.8	6.4	7.2	7.9	8.5	9.1	9.7
DX1-A22		8	9	9.8	10.6	11.3	12	7.9	8.8	9.7	10.4	11.2	11.8	7.7	8.7	9.5	10.2	10.9	11.6
DX1-A24		9.5	10.6	11.7	12.6	13.5	14.3	9.4	10.5	11.5	12.4	13.2	14	9.2	10.3	11.3	12.2	13	13.8
DX1-A28		13	14.5	15.9	17.1	18.3	19.4	12.8	14.3	15.6	16.9	18	19.1	12.5	14	15.3	16.6	17.7	18.8
DX1-A30		14.2	15.8	17.3	18.7	20	21.2	13.9	15.6	17.1	18.4	19.7	20.9	13.7	15.3	16.7	18.1	19.3	20.5
DX1-A32	15.2	17	18.6	20.1	21.5	22.8	15	16.7	18.3	19.8	21.2	22.4	14.7	16.4	18	19.4	20.8	22	

R32扩展冷量表:

阀体 型号	蒸发温度[°C]	15						10						5					
	冷凝温度[°C]	28.1	33.5	38.4	42.9	47.1	51	24.3	30.1	35.4	40.1	44.5	48.5	20.7	26.9	32.5	37.5	42.1	46.3
	ΔP [MPa]	0.55	0.83	1.1	1.38	1.65	1.93	0.55	0.83	1.1	1.38	1.65	1.93	0.55	0.83	1.1	1.38	1.65	1.93
DX1-A13	扩展冷量 [kW]	6.8	7.9	8.8	9.6	10.4	11.1	7	8.1	9	9.9	10.7	11.4	7.1	8.3	9.2	10.1	10.9	11.7
DX1-A16		11	12.7	14.2	15.6	16.8	18	11.3	13	14.6	16	17.2	18.4	11.5	13.3	14.9	16.3	17.6	18.8
DX1-A18		13.3	15.4	17.2	18.8	20.3	21.7	13.6	15.8	17.6	19.3	20.8	22.3	13.9	16.1	18	19.7	21.3	22.8
DX1-A20		16.3	18.8	21	23	24.9	26.6	16.7	19.3	21.6	23.6	25.5	27.3	17.1	19.7	22	24.1	26.1	27.9
DX1-A22		19.6	22.6	25.3	27.7	29.9	32	20.1	23.2	25.9	28.4	30.7	32.8	20.5	23.7	26.5	29	31.3	33.5
DX1-A24		23.3	26.9	30.1	33	35.6	38.1	23.9	27.6	30.9	33.8	36.5	39	24.4	28.2	31.5	34.6	37.3	39.9
DX1-A28		31.8	36.7	41	45	48.6	51.9	32.6	37.6	42.1	46.1	49.8	53.2	33.3	38.5	43	47.1	50.9	54.4
DX1-A30		34.7	40	44.7	49	52.9	56.6	35.5	41	45.9	50.2	54.3	58	36.3	41.9	46.9	51.3	55.5	59.3
DX1-A32		37.3	43.1	48.1	52.7	57	60.9	38.2	44.1	49.4	54.1	58.4	62.4	39.1	45.1	50.4	55.3	59.7	63.8
阀体 型号		蒸发温度[°C]	0						-5						-10				
	冷凝温度[°C]	17.2	23.9	29.8	35.1	39.8	44.2	13.9	21.1	27.3	32.8	37.8	42.3	10.8	18.4	24.9	30.7	35.9	40.6
	ΔP [MPa]	0.55	0.83	1.1	1.38	1.65	1.93	0.55	0.83	1.1	1.38	1.65	1.93	0.55	0.83	1.1	1.38	1.65	1.93
DX1-A13	扩展冷量 [kW]	7.3	8.4	9.4	10.3	11.1	11.9	7.4	8.5	9.5	10.5	11.3	12.1	7.5	8.7	9.7	10.6	11.5	12.2
DX1-A16		11.7	13.6	15.2	16.6	17.9	19.2	11.9	13.8	15.4	16.9	18.2	19.5	12.1	14	15.6	17.1	18.5	19.7
DX1-A18		14.2	16.4	18.3	20.1	21.7	23.2	14.4	16.7	18.6	20.4	22.1	23.6	14.6	16.9	18.9	20.7	22.3	23.9
DX1-A20		17.4	20.1	22.4	24.6	26.5	28.4	17.7	20.4	22.8	25	27	28.8	17.9	20.7	23.1	25.3	27.3	29.2
DX1-A22		20.9	24.1	27	29.6	31.9	34.1	21.2	24.5	27.4	30	32.4	34.7	21.5	24.9	27.8	30.4	32.9	35.1
DX1-A24		24.9	28.7	32.1	35.2	38	40.6	25.3	29.2	32.7	35.8	38.6	41.3	25.6	29.6	33.1	36.3	39.2	41.9
DX1-A28		33.9	39.2	43.8	48	51.8	55.4	34.5	39.8	44.5	48.8	52.7	56.3	34.9	40.4	45.1	49.4	53.4	57.1
DX1-A30		37	42.7	47.8	52.3	56.5	60.4	37.6	43.4	48.5	53.1	57.4	61.4	38.1	44	49.2	53.9	58.2	62.2
DX1-A32		39.8	46	51.4	56.3	60.8	65	40.4	46.7	52.2	57.2	61.8	66	41	47.3	52.9	58	62.6	66.9
阀体 型号		蒸发温度[°C]	-15						-20						-25				
	冷凝温度[°C]	7.9	15.9	22.8	28.8	34.1	39	13.7	20.8	27.1	32.6	37.6	42.2	11.6	19.1	25.5	31.2	36.4	41
	ΔP [MPa]	0.55	0.83	1.1	1.38	1.65	1.93	0.83	1.1	1.38	1.65	1.93	2.21	0.83	1.1	1.38	1.65	1.93	2.21
DX1-A13	扩展冷量 [kW]	7.6	8.8	9.8	10.7	11.6	12.4	8.8	9.9	10.8	11.7	12.5	13.2	8.9	9.9	10.9	11.8	12.6	13.3
DX1-A16		12.2	14.1	15.8	17.3	18.7	20	14.2	15.9	17.4	18.8	20.1	21.4	14.3	16	17.6	19	20.3	21.5
DX1-A18		14.8	17.1	19.1	20.9	22.6	24.2	17.2	19.3	21.1	22.8	24.4	25.9	17.4	19.4	21.3	23	24.5	26
DX1-A20		18.1	20.9	23.4	25.6	27.6	29.5	21.1	23.6	25.8	27.9	29.8	31.6	21.2	23.7	26	28.1	30	31.8
DX1-A22		21.8	25.1	28.1	30.8	33.2	35.5	25.4	28.3	31.1	33.5	35.9	38	25.5	28.5	31.3	33.8	36.1	38.3
DX1-A24		25.9	29.9	33.5	36.7	39.6	42.3	30.2	33.8	37	39.9	42.7	45.3	30.4	34	37.2	40.2	43	45.6
DX1-A28		35.3	40.8	45.6	50	54	57.7	41.2	46	50.4	54.5	58.2	61.7	41.4	46.3	50.8	54.8	58.6	62.2
DX1-A30		38.5	44.5	49.7	54.5	58.8	62.9	44.9	50.2	55	59.4	63.5	67.3	45.2	50.5	55.3	59.8	63.9	67.8
DX1-A32		41.4	47.9	53.5	58.6	63.3	67.7	48.3	54	59.1	63.9	68.3	72.4	48.6	54.4	59.5	64.3	68.8	72.9
阀体 型号		蒸发温度[°C]	-30						-35						-40				
	冷凝温度[°C]	9.8	17.5	24.2	30	35.3	40	8.2	16.2	23	29	34.3	39.2	6.8	15	22	28.1	33.5	38.4
	ΔP [MPa]	0.83	1.1	1.38	1.65	1.93	2.21	0.83	1.1	1.38	1.65	1.93	2.21	0.83	1.1	1.38	1.65	1.93	2.21
DX1-A13	扩展冷量 [kW]	8.9	10	10.9	11.8	12.6	13.4	9	10	11	11.9	12.7	13.4	9	10	11	11.9	12.7	13.5
DX1-A16		14.4	16.1	17.6	19.1	20.4	21.6	14.5	16.2	17.7	19.1	20.4	21.7	14.5	16.2	17.7	19.1	20.5	21.7
DX1-A18		17.4	19.5	21.4	23.1	24.7	26.2	17.5	19.6	21.4	23.1	24.7	26.2	17.5	19.6	21.4	23.2	24.8	26.3
DX1-A20		21.3	23.8	26.1	28.2	30.2	32	21.4	23.9	26.2	28.3	30.2	32.1	21.4	23.9	26.2	28.3	30.3	32.1
DX1-A22		25.6	28.7	31.4	33.9	36.3	38.5	25.7	28.8	31.5	34	36.4	38.6	25.8	28.8	31.5	34.1	36.4	38.6
DX1-A24		30.5	34.2	37.4	40.4	43.2	45.8	30.6	34.3	37.5	40.5	43.3	46	30.7	34.3	37.6	40.6	43.4	46
DX1-A28		41.6	46.6	51	55.1	58.9	62.5	41.8	46.7	51.2	55.3	59.1	62.6	41.8	46.7	51.2	55.3	59.1	62.7
DX1-A30		45.4	50.7	55.6	60	64.2	68.1	45.5	50.9	55.8	60.2	64.4	68.3	45.6	51	55.8	60.3	64.5	68.4
DX1-A32		48.8	54.6	59.8	64.6	69.1	73.3	49	54.8	60	64.8	69.3	73.5	49	54.8	60.1	64.9	69.4	73.6

流体温度修正系数

冷媒	EXV 入口流体温度 (°C)										
	4	10	16	21	27	32	38	43	49	54	60
R-22	1.26	1.22	1.18	1.13	1.09	1.05	1	0.95	0.91	0.86	0.81
R-407C	1.31	1.26	1.21	1.16	1.11	1.06	1	0.94	0.89	0.83	0.76
R-410A	1.34	1.28	1.23	1.18	1.12	1.06	1	0.94	0.87	0.8	0.72
R-134a	1.32	1.27	1.21	1.16	1.11	1.06	1	0.94	0.89	0.83	0.77
R-404A	1.46	1.39	1.31	1.24	1.16	1.08	1	0.92	0.83	0.73	0.63
R32	1.26	1.22	1.18	1.13	1.09	1.05	1	0.95	0.9	0.85	0.79